

Needle Valves & Manifolds

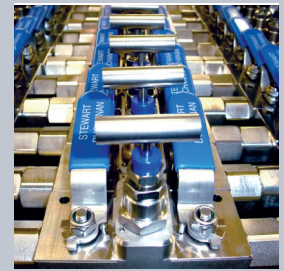
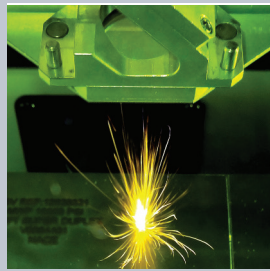

About Us

At Stewart-Buchanan Gauges Ltd, our aim is to continually develop a company which is already dedicated to the needs of its customers through our market-leading product innovation and renowned quality levels.

We became an Employee-owned Company in December 2011, and since then we have enjoyed further growth and success across highly competitive markets within Europe and Worldwide.

The Stewarts Group was originally established in 1870's Glasgow and has developed an enviable reputation for the manufacture of technically advanced products incorporating high-quality and innovative design.

At our production facility located near Glasgow, Scotland, we employ over 160 people in our 4,000 m² manufacturing plant which features the latest state of the art Manufacturing Resource Planning system (MRP II), 3D design, CNC machinery and manufacturing techniques.

VISION STATEMENT

An employee owned company responding to customer demands while setting the standards for Safety, Quality and Reliability.

MISSION STATEMENT

To recognize and exceed customer expectations. To build a strong ownership culture to create sustainable employment and the opportunity for each employee to contribute and succeed.

WE DESIGN & MANUFACTURE:

- Pressure Gauges
- Temperature Gauges
- High Pressure Needle & Ball Valves
- Needle Valve & Ball Valve Manifolds
- Monoflanges & Slim Line Monoflanges
- Double Block & Bleed Valves
- Injection Valves
- Sampling Valves
- Distribution Manifolds & Instrumentation
- Panel & Instrument Assemblies/Enclosures

MAIN MARKETS

Our main markets include, but are not limited to:

- Oil and Petrochemical
- Gas and Compressed Air
- Power Generation
- Original Equipment Manufacturers (OEM)
- Food and Beverage
- Hydraulic
- Heating and Ventilation
- Test and Inspection
- Manufacturing Process

VALVES & MANIFOLDS AT A GLANCE



Stewarts

Offers a variety of precision engineered valves and 2, 3, and 5-valve Manifolds in Direct and Remote Mount styles with vent configurations to meet most flow, pressure and level measurement application requirements.

Stewarts 2-valve manifolds are designed for static pressure and liquid level applications; the 3 and 5 valve manifolds are well suited for use with most differential pressure transmitters and can accept both female and flange process impulse line connections.

Stewarts work extensively with a large proportion of its clients in customising designs and configurations. We are well equipped to reproduce any "special" valve manifold manufactured in the past. We will also work with any client in tailoring and producing a precision product with any number of valves; configured to meet the specific requirements of the system. Also available from Stewarts is the G series range of valves for high pressure applications with design pressures currently to 20,000 and 30,000 psi. Please see the G series catalogue for full details.

STEWARTS Valves & Manifolds have been designed to provide the safest possible connection and mounting of instruments.

STANDARD FEATURES

- 6000psi standard Maximum Working Pressure
- Hydrostatically tested to 1.5 times Maximum Working Pressure. In accordance with EN 12266
- Full 316/316L St.St. Dual Certified, compliant to ISO 15156/NACE MR-01-75 & Norsok M-630
- Valves have trace code on body with original mill certificates available all to EN 10204-3.1
- High Tolerance NPT Thread Engagement with 5-6 threads engaged when fully tightened
- All valves and manifolds are individually boxed for protection and storage
- Laser etching – valve detail on body
- Bonnet locking pin safely locks the bonnet to body
- Ø 4.76 Standard tip thru bore (CV = 0.4) Fully open

PRESSURE EQUIPMENT DIRECTIVE 97/23/EC

Due to internal bore size and internal volumes up to and including 25mm, products offered in this catalogue comply with S.E.P (Sound Engineering Practice) article 3, paragraph 3 of the Pressure Equipment Directive P.E.D. 97/23/EC and therefore CE marking is not applicable.

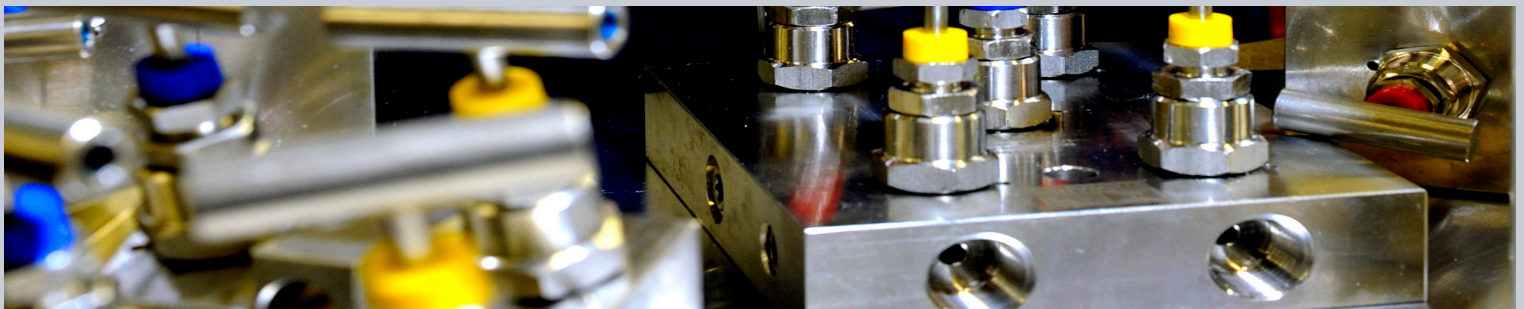

Stewarts - USA, LLC

6786 Tipperary, Houston, Texas 77061 USA
info@stewartusa.com

DATA SHEET REF: Needlevalve & Manifold At a Glance-REV01-15 SUSA

Phone: 713.643.1022. Fax: 713.643.2855. Toll Free: 800.901.1316

Web: www.STEWARTSUSA.com



TECHNICAL SPECIFICATION

NEEDLE VALVE

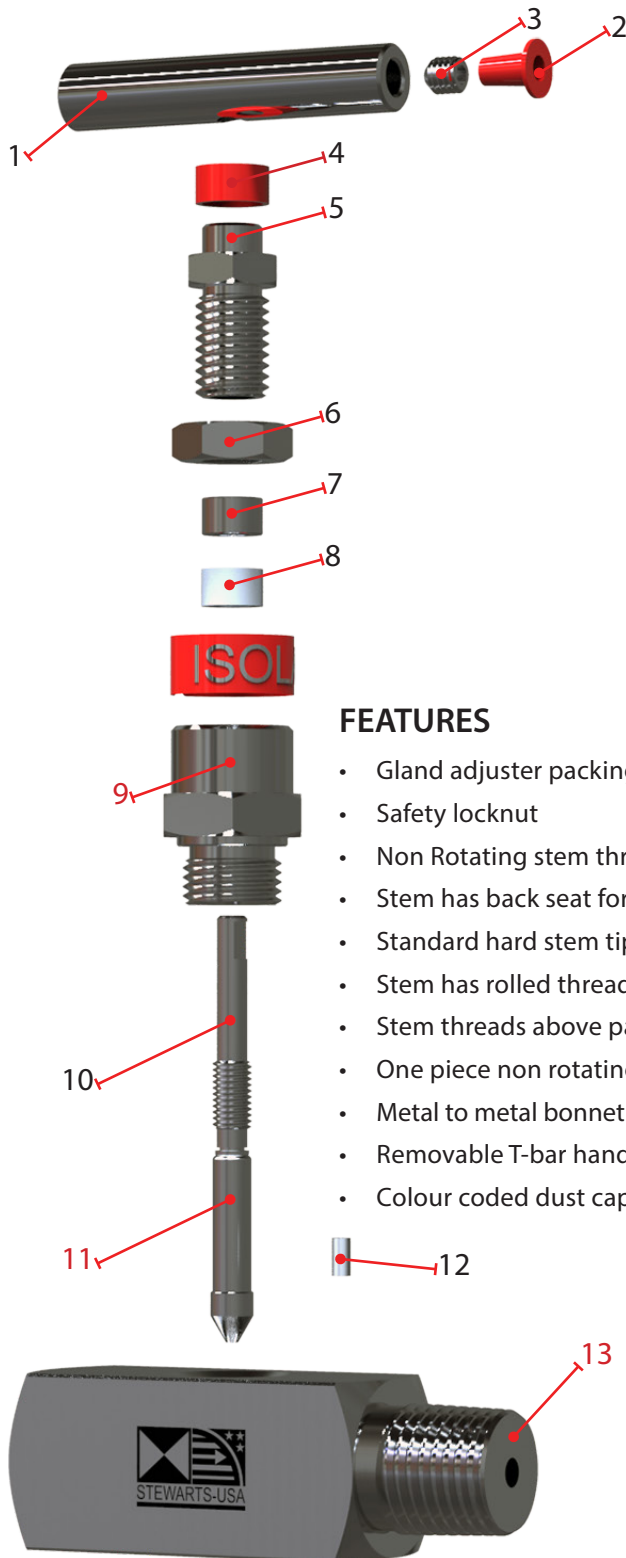

DESCRIPTION / MATERIAL

1/	T Bar Handle	316/316L St.St (Dual Cert)
2/	Colour Coded Dust Plug	Polyethylene (LDPE)
3/	Locking screw	304 St.St
4/	Colour Coded Dust Cap	Polyethylene (LDPE)
5/	Gland Adjuster	316/316L St.St (Dual Cert)
6/	Safety Locknut	316/316L St.St (Dual Cert)
7/	Compression Ring	316/316L St.St (Dual Cert)
8/	Packing	PTFE or Graphoil
9/	Valve Bonnet	316/316L St.St (Dual Cert)
10/	Stem Rotating	316/316L St.St (Dual Cert)
11/	Stem Non Rotating	316/316L St.St (Dual Cert)
12/	Locking Pin	304 St.St
13/	Body	316/316L St.St (Dual Cert)

N.B. Wetted parts 9,11, & 13 shown in red

FEATURES

- Gland adjuster packing seal can be externally adjusted in service
- Safety locknut
- Non Rotating stem through packing giving ease of operation & less packing wear
- Stem has back seat for added anti-blow out security
- Standard hard stem tip for effective shut-off
- Stem has rolled threads for smooth action, strength, & long life
- Stem threads above packing, no process contamination or lube washout
- One piece non rotating stem tip joint, located above packing, cannot work free
- Metal to metal bonnet seal suitable for high pressure / temperature applications
- Removable T-bar handle
- Colour coded dust cap on stem prevents ingress of contamination & protects actuating threads

Stewarts - USA, LLC

6786 Tipperary, Houston, Texas 77061 USA
info@stewartusa.com

DATA SHEET REF: Needle Technical Specification REV01-15 SUSA

Phone: 713.643.1022. Fax: 713.643.2855. Toll Free: 800.901.1316

Web: www.STEWARTSUSA.com



TECHNICAL SPECIFICATION

NEEDLE VALVE



OPTIONAL FEATURES

- Valves can be supplied to ISO 15156/NACE MR-01-75 or NORSOK M-630 specifications
- PMI - Certified material identification XRF (See data sheet)
- Cleaned and degreased for Oxygen service (or Oxidizing Gases)
- Needle valve available in right angled form
- Wide variety of process connections available by arrangement
- Isolating tip as standard, metering tip available on request
- PCTFE (KEL-F) Soft tip option available for special application (Max working temperature = 120°C)
- Panel mounting valve, where available, on request
- Laser etching – customisable options available
- Ø 3.2 Metering tip thru bore (CV = 0.32) Fully open
- Ø 10 Large tip thru bore (CV = 1.7) Fully open
- Firesafe certification to BS EN ISO 10497 (BS 6755 Part 2), API 607, API 6FA, where available
- 10,000psi optional designs, where available
- Choice of exotic alloys i.e., MONEL®, Duplex, Super Duplex, Titanium, HASTELLOYS®, Alloys 625, 825, 6%Mo
- All NORSOK M-630 materials sourced from NORSOK M-650 approved mills on request
- Optional mounting bracket kits, where available



- Packing adjustment may be required during the service life of the valves.
- Valves that have not been cycled over a period of time may have a higher initial actuation torque.

PRESSURE TEMPERATURE CHART

Hard Stem Tip As Standard

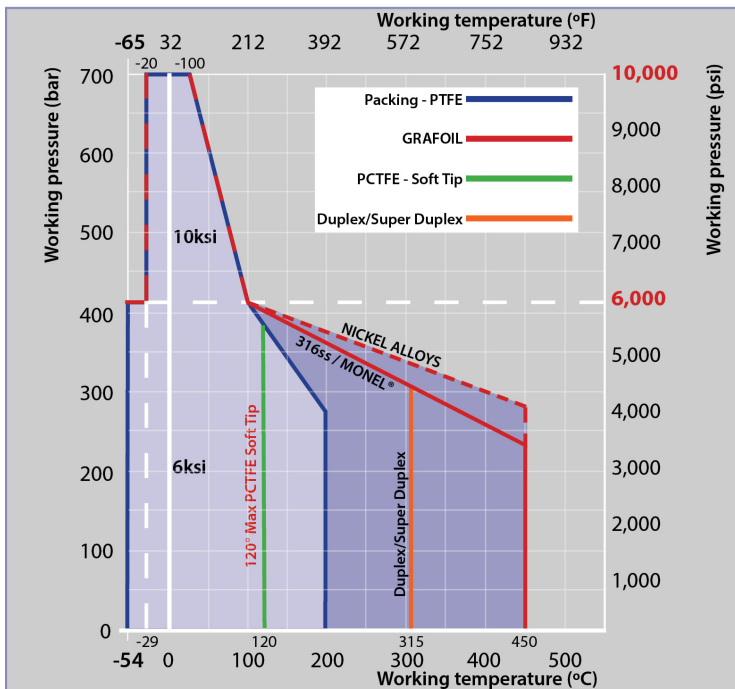

Pressure-Temperature Rating Needle Valves

PTFE PACKING

Maximum pressure 10000 psi (690 bar) at 100° F (38° C)
Maximum pressure 6000 psi (413 bar) at 212° F (100° C)
Maximum pressure 4000 psi (275 bar) at 392° F (200° C)
(PTFE packing rated to maximum temperature of 392° F (200° C))

GRAFOIL® PACKING

Maximum pressure 10000 psi (690 bar) at 100° F (38° C)
Maximum pressure 6000 psi (413 bar) at 212° F (100° C)
Maximum pressure 3300 psi (230 bar) at 842° F (450° C)

PCTFE Soft Tip

Maximum pressure 6000 psi (413 bar) at 212° F (100° C)
Maximum pressure 5500 psi (380 bar) at 248° F (120° C)

Duplex / Super Duplex

Limited to 600° F (315° C)

Stewarts - USA, LLC

6786 Tipperary, Houston, Texas 77061 USA
info@stewartusa.com

DATA SHEET REF: Needle Technical Specification REV01-15 SUS4

Phone: 713.643.1022. Fax: 713.643.2855. Toll Free: 800.901.1316

Web: www.STEWARTSUSA.com



NOTES

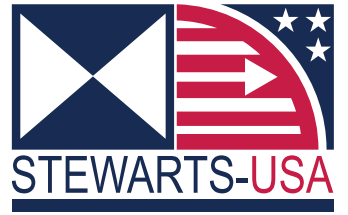

Stewarts - USA, LLC

6786 Tipperary, Houston, Texas 77061 USA
info@stewartsusa.com

DATA SHEET REF: NOTES -REV01-15 SUSAA

Phone: 713.643.1022. Fax: 713.643.2855. Toll Free: 800.901.1316

Web: www.STEWARTSUSA.com

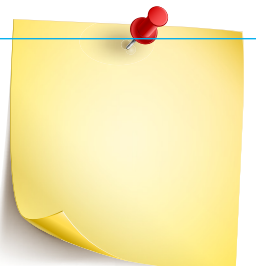

HOW TO ORDER

NEEDLE VALVES & MANIFOLDS

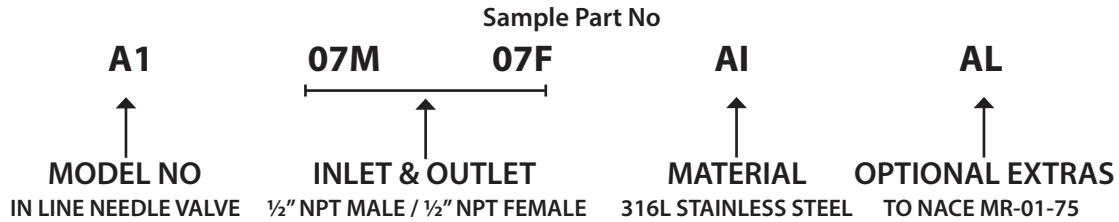

Inlet & Outlet	
M = Male	F = Female Thread
02M or F	= G½B or G½(BSPP)
03M or F	= ¼" NPT
04M or F	= G¼B or G¼ (BSPP)
05M or F	= ⅜" NPT
06M or F	= G¾B or G¾(BSPP)
07M or F	= ½" NPT
08M or F	= G½B or G½ (BSPP)
09M or F	= ¾" NPT
10M or F	= G¾B or G¾ (BSPP)
11M or F	= 1" NPT
12M or F	= G1B or G1 (BSPP)
13M or F	= R¼ or Rc¼ (BSPT)
14M or F	= R¾ or Rc¾(BSPT)
15M or F	= R½ or Rc½ (BSPT)
16M or F	= R¾ or Rc¾ (BSPT)
17M or F	= R1 or Rc1 (BSPT)
18M or F	= R¾ or Rc¾(BSPT)
Direct Mount Outlets	
DMA	= IEC Type A
DIR	= IEC Type B
Key	
GxB	= Parallel Male Class B
G	= Parallel Female
R	= Taper Male
Rc	= Taper Female

Material	
AI = 316L Stainless Steel (UNS S31600 / S31603)	
MO = MONEL® 400 (UNS N04400)	
HA = HASTELLOY® C-276 ® (UNS N10276)	
IL = INCONEL® 625 (UNS N06625)	
IN = INCOLOY® 825 (UNS N08825)	
TI = TITANIUM Gr.2 (UNS R50400)	
DU = DUPLEX (UNS S31803)	
SD = SUPER DUPLEX (UNS S32760)	
HC = HASTELLOY® C-22 (UNS N06022)	
SA = SUPER AUSTENITIC ST.ST 6%Mo (UNS S31254)	
Note: Other materials available on request.	

Optional Extras
AA = Black Hand Wheel
AB = Anti Tamper Bonnet with Key
AC = Panel Mount Nut on Bonnet
AD = Lockable Handle With Padlock
AE = Captive Bleed Valve
AF = Surface Mount Tapped Holes
AG = Lockable Handle Without Padlock
AH = Captive Bleed Nut
AJ = Metering Tip
AK = Rated 700 bar / 10,000 psi (Dimensions available on request)
AL = To Nace MR-01-75 (ISO 15156 Latest Edition)
AM = Degreased to Oxygen Standard
AN = KEL-F Soft Tip
AO = Graphoil Packing
AP = Complete with 56mm Hole Centres (Outlet)
AQ = Complete with Yoke Mounting Bracket for 2 inch N.B (60.3 mm dia Stand Pipe)
AR = Complete with Vent Plugs
AS = Complete with 65 mm Hole Centres (Outlet)
AT = Complete with M10 x 1.5 pitch x 55mm Long Stainless Steel Bolts
AU = Complete with 58.7 mm Hole Centres (Outlet)
AV = Degreased
AW = Complete with M12 x 1.75 pitch x 55mm Long Stainless Steel Bolts
AX = Fire Safe
AY = Rising Plug Type Tip
AZ = NORSOK M630 (Latest edition)
BA = ¼" NPT Vent plug
BB = Lockable Anti Tamper Bonnet with Key

Stewarts - USA, LLC

6786 Tipperary, Houston, Texas 77061 USA
 info@stewartsusa.com

DATA SHEET REF: howtoorder-REV01-15 SUSA

Phone: 713.643.1022. Fax: 713.643.2855. Toll Free: 800.901.1316

Web: www.STEWARTSUSA.com



OPTIONAL EXTRAS



SUFFIX-AA
Black Hand Wheel



SUFFIX-AB
Anti Tamper Bonnet with Key

SUFFIX-BB
Lockable Anti Tamper Bonnet with Key



SUFFIX-AC
Panel Mount Nut on Bonnet

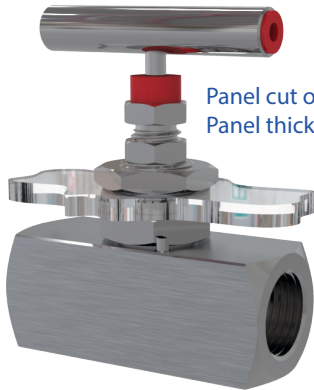

Panel cut out \varnothing 0.75 inches (19mm)
Panel thickness 0.12 to 0.2 inches (3 to 5 mm)

SUFFIX-AD
Lockable Handle with Padlock

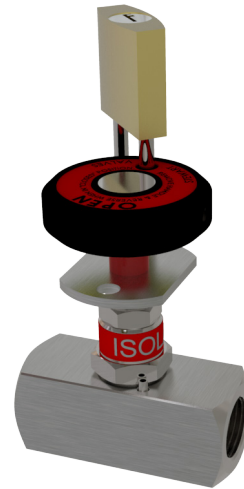

SUFFIX-AE
Captive Bleed Valve

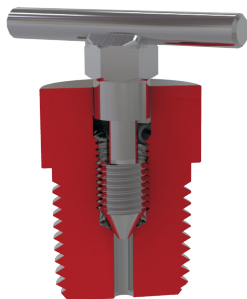

SUFFIX-AH
Captive Bleed Nut



Stewarts - USA, LLC

6786 Tipperary, Houston, Texas 77061 USA
info@stewartsusa.com

DATA SHEET REF: Optional Extras-REV01-15 SUSA

Phone: 713.643.1022. Fax: 713.643.2855. Toll Free: 800.901.1316

Web: www.STEWARTSUSA.com



HAND & GAUGE VALVES



STEWARTS Hand & Gauge Valves. come in different shapes and sizes with various thread forms available. High quality; precision engineered products; they are versatile and can be utilised for shut off in any part of the pressure system, whether it be for instrument, branch, loop or other isolation functions. With numerous add-on's and customisable features they can be used with other Stewarts products, or by themselves, to create the perfect solution with safety and quality assured.

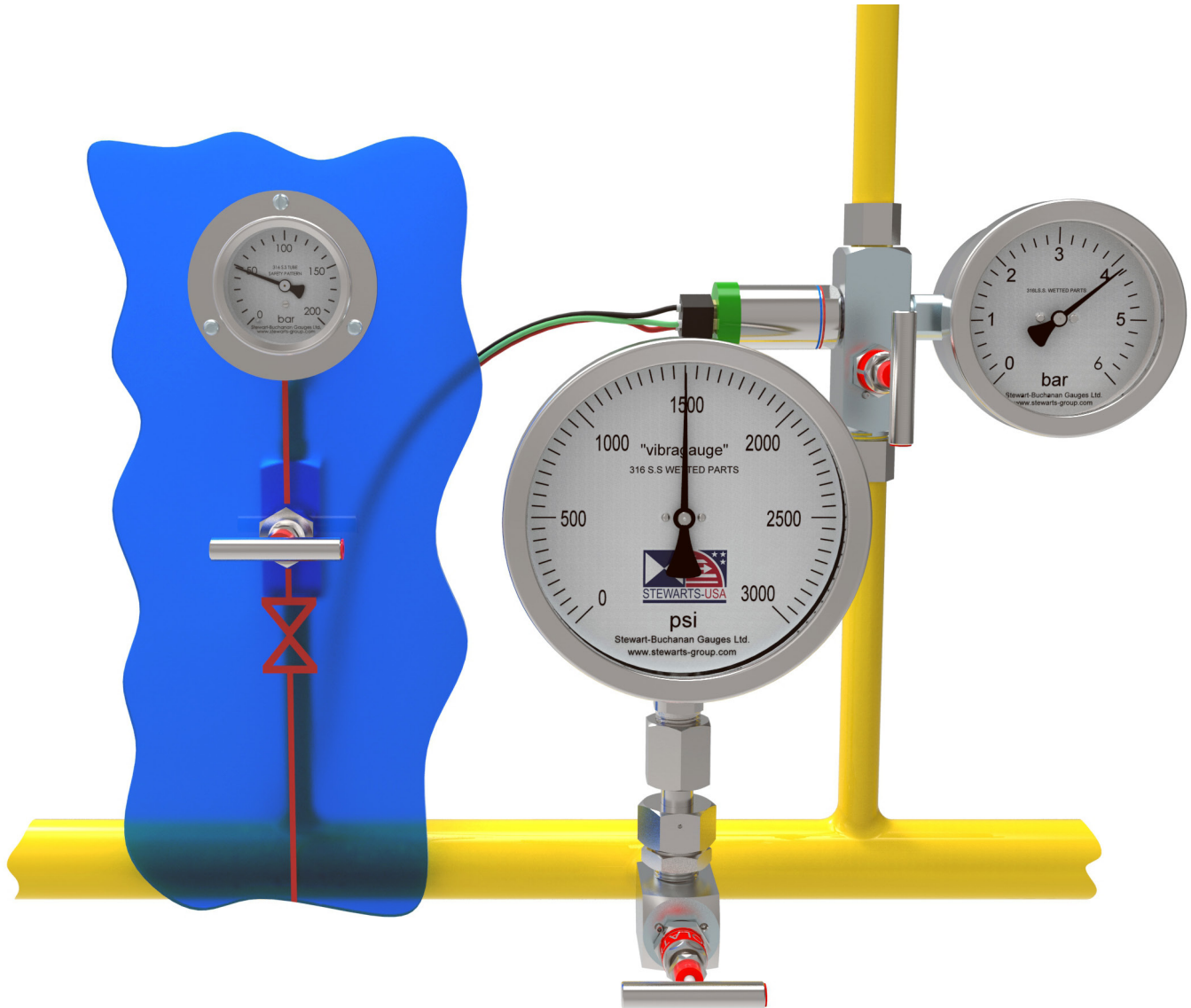

Disclaimer:- Process pipework and structure in the above is for illustration purposes only; it does not reflect full requirement of a system installation and additional parts may be necessary.

Stewarts - USA, LLC

6786 Tipperary, Houston, Texas 77061 USA
info@stewartusa.com

DATA SHEET REF: SingleDivider-REV01-15 SUSA

Phone: 713.643.1022. Fax: 713.643.2855. Toll Free: 800.901.1316

Web: www.STEWARTSUSA.com



MODEL - A1

SINGLE BLOCK (Female / Female)
HAND VALVE 413 bar (6000 psi)

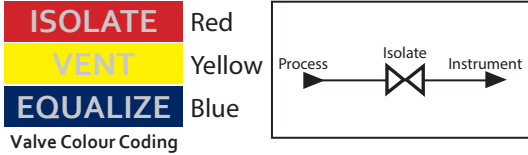

APPLICATION

High Integrity instrument isolation of pressure gauges and pressure transmitters.
Also available in a range of other materials and options
(See HOW TO ORDER Data Sheet).



Weight = 1.1 lbs (0.5 kg)

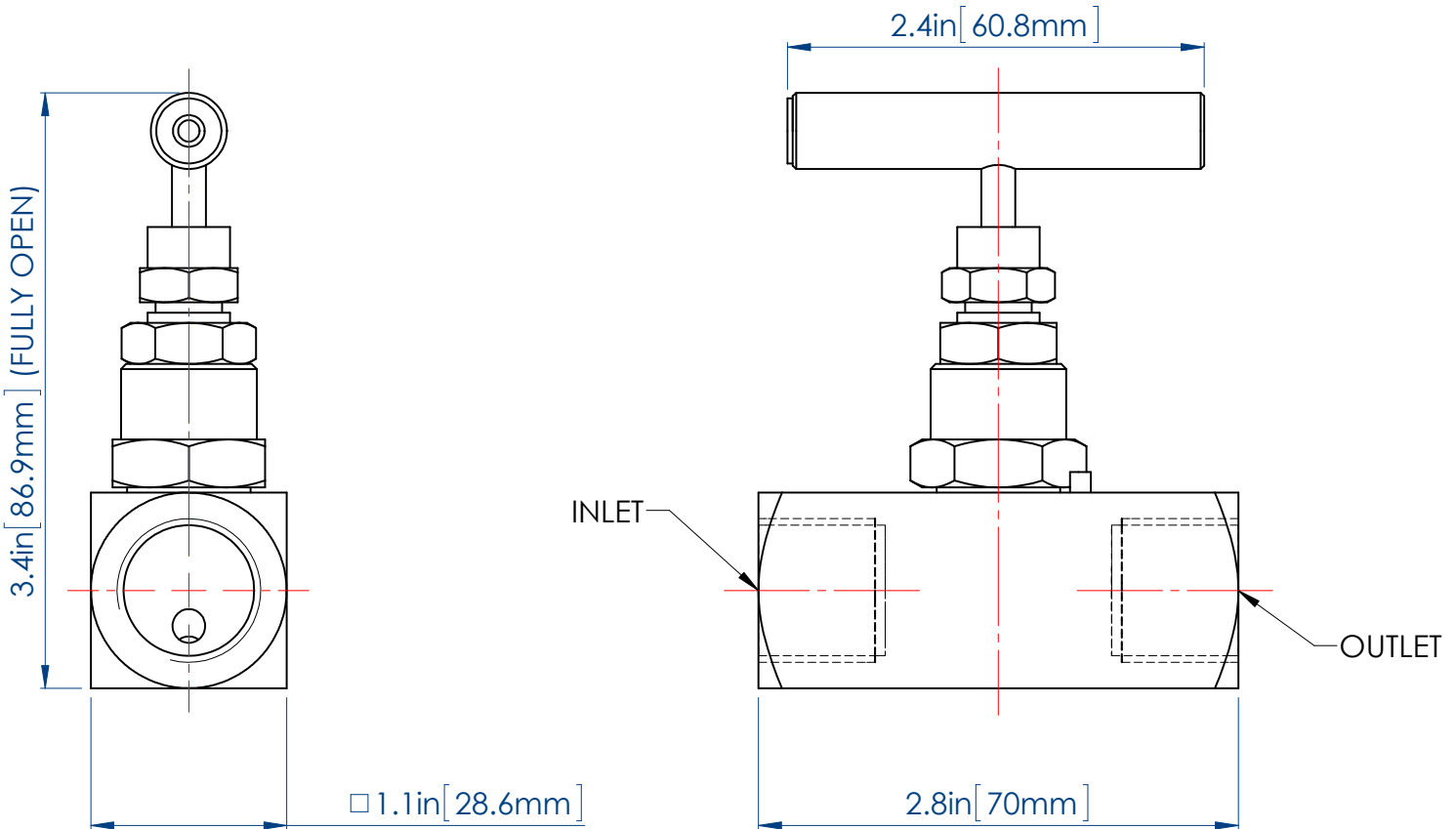

Dimensions shown in inches & mm

Stewarts - USA, LLC

6786 Tipperary, Houston, Texas 77061 USA
info@stewartsusa.com

DATA SHEET REF: A1FF-REV01-15 SUS304

Phone: 713.643.1022. Fax: 713.643.2855. Toll Free: 800.901.1316

Web: www.STEWARTSUSA.com



MODEL - A1

**SINGLE BLOCK (Male / Female)
HAND VALVE** 413 bar (6000 psi)



ISOLATE	Red
VENT	Yellow
EQUALIZE	Blue

Valve Colour Coding

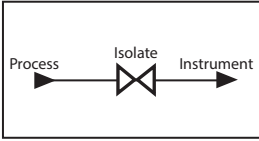

APPLICATION

High Integrity instrument isolation of pressure gauges and pressure transmitters.
Also available in a range of other materials and options
(See HOW TO ORDER Data Sheet).



Weight = 1.1 lbs (0.5 kg)

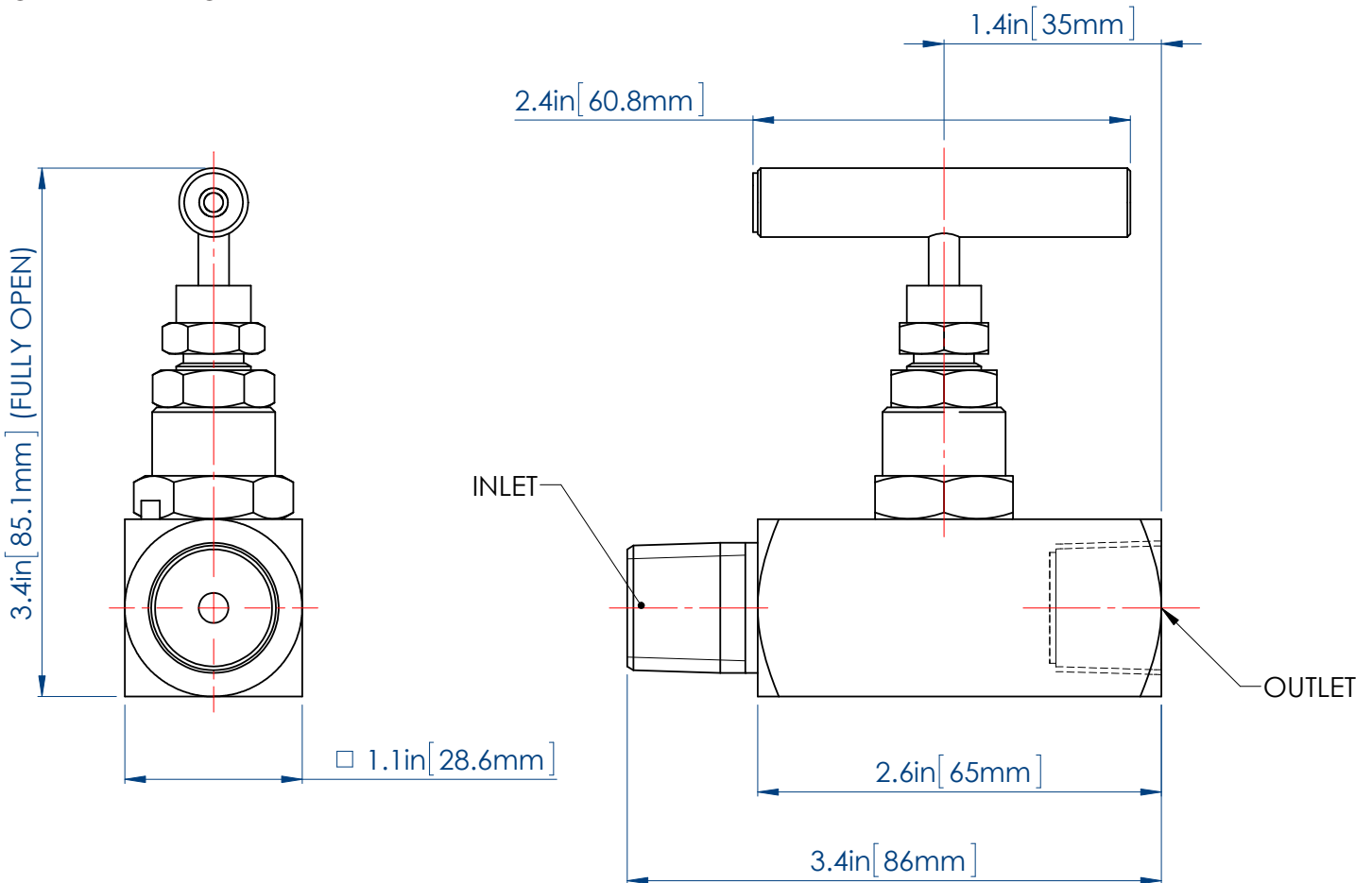

Dimensions shown in inches & mm

Stewarts - USA, LLC

6786 Tipperary, Houston, Texas 77061 USA
info@stewartsusa.com

DATA SHEET REF: A1MF-REV01-15 SUSA

Phone: 713.643.1022. Fax: 713.643.2855. Toll Free: 800.901.1316

Web: www.STEWARTSUSA.com



MODEL - B1

SINGLE BLOCK (Right Angled) HAND VALVE 413 bar (6000 psi)

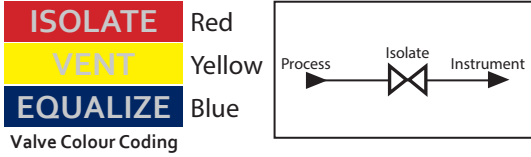

APPLICATION

High Integrity instrument isolation of pressure gauges and pressure transmitters.
Also available in a range of other materials and options
(See HOW TO ORDER Data Sheet).



Weight = 1.3 lbs (0.6 kg)

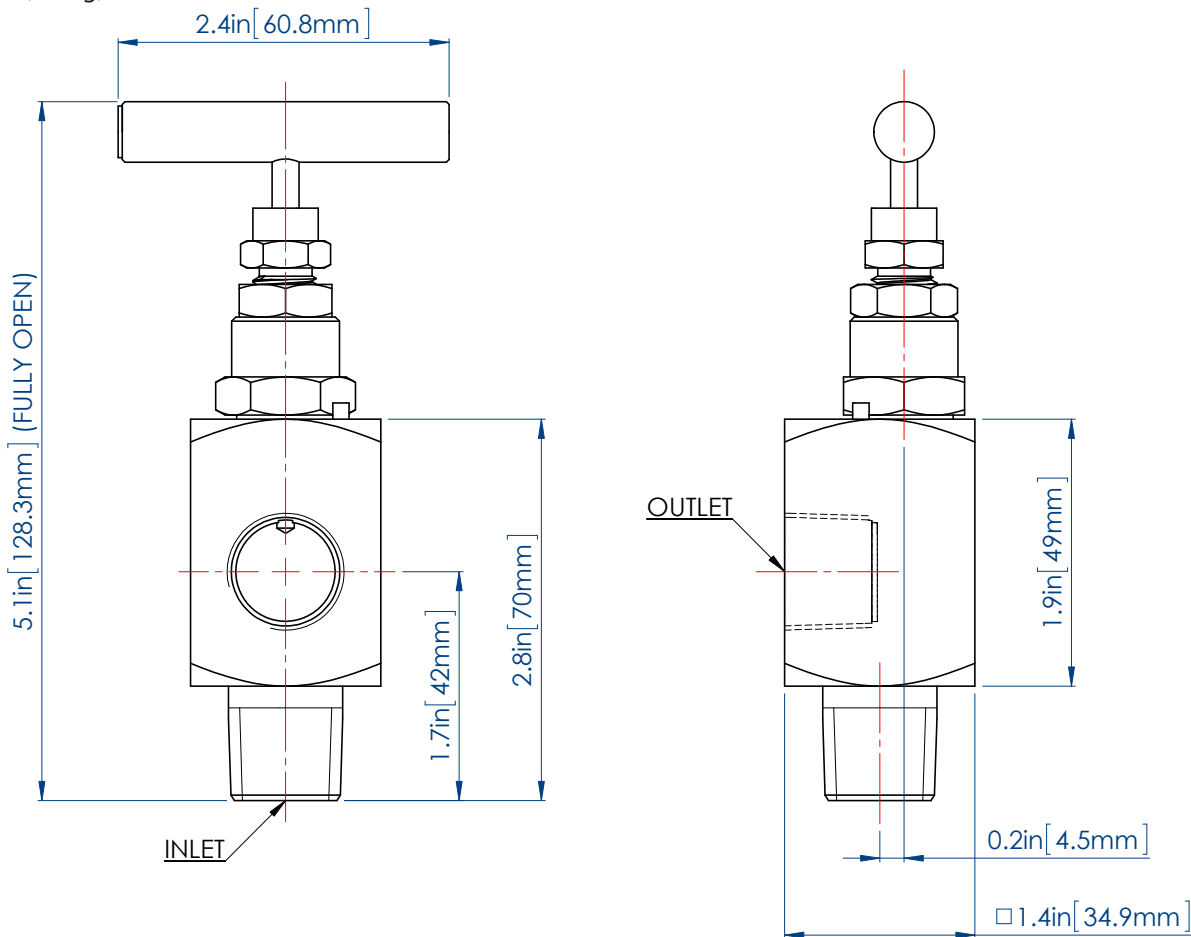

Dimensions shown in inches & mm

Stewarts - USA, LLC

6786 Tipperary, Houston, Texas 77061 USA
info@stewartsusa.com

DATA SHEET REF: B1-REV01-15 SUSA

Phone: 713.643.1022. Fax: 713.643.2855. Toll Free: 800.901.1316

Web: www.STEWARTSUSA.com



MODEL - C1

SINGLE BLOCK FORGED (In Line) HAND VALVE 1000 bar (15000 psi)

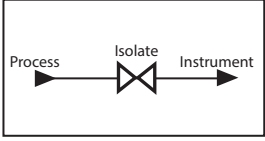

APPLICATION

High Integrity instrument isolation of pressure gauges and pressure transmitters.
Only available in 316SS or Carbon Steel (with Plated option).
(See HOW TO ORDER Data Sheet).

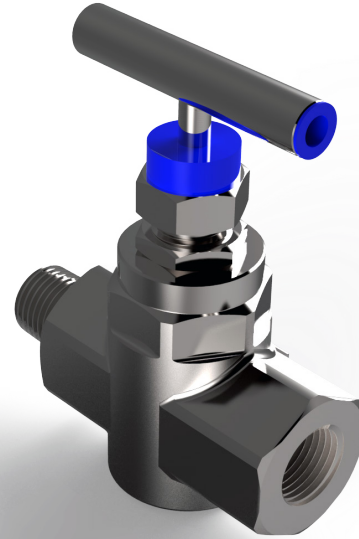

Weight = 2.4 lbs (1.1 kg)

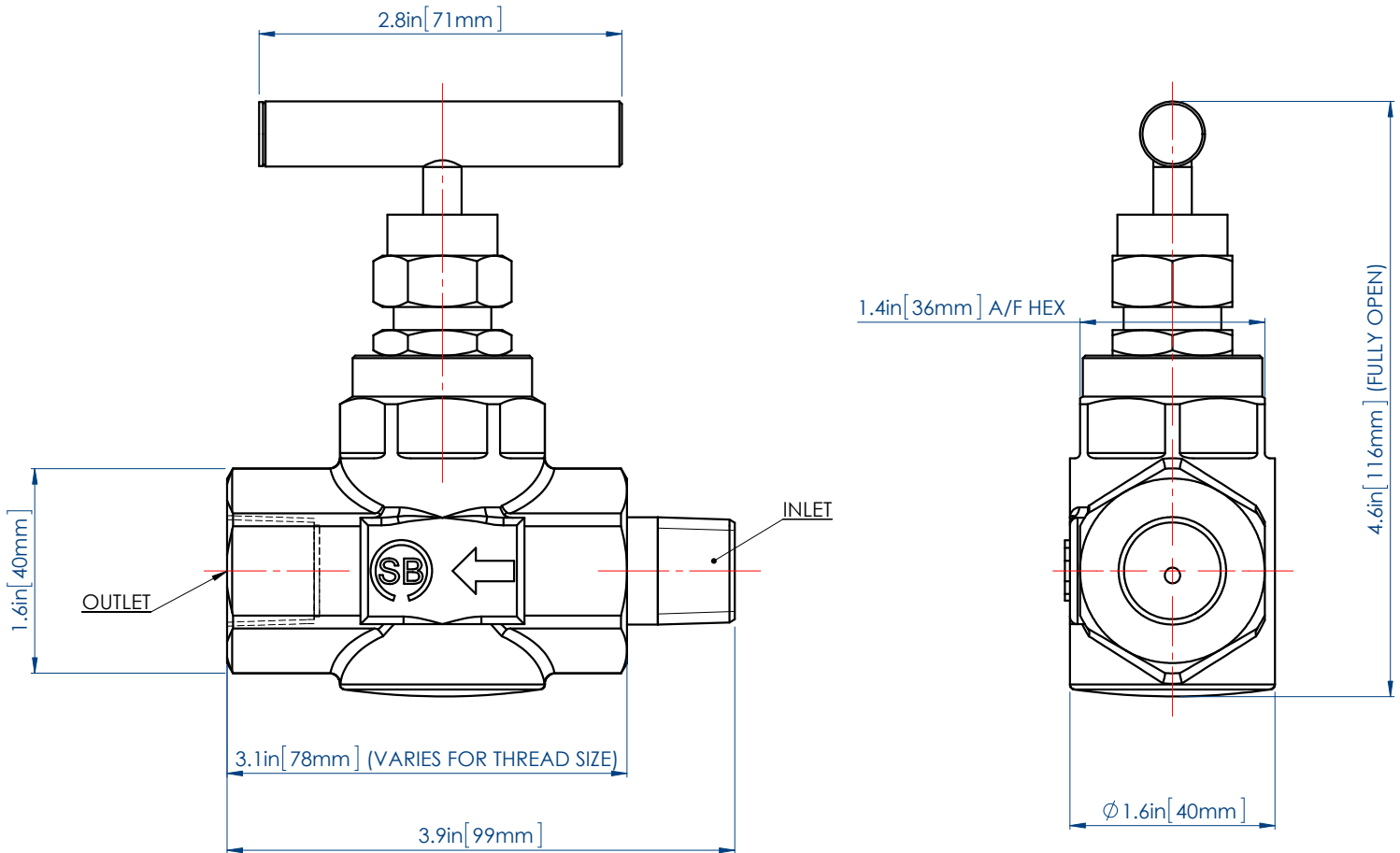

Dimensions shown in inches & mm

Stewarts - USA, LLC

6786 Tipperary, Houston, Texas 77061 USA
info@stewartsusa.com

DATA SHEET REF: C1-REV01-15 SUSA

Phone: 713.643.1022. Fax: 713.643.2855. Toll Free: 800.901.1316

Web: www.STEWARTSUSA.com



MODEL - D1

SINGLE BLOCK FORGED (Right Angled) HAND VALVE 1000 bar (15000 psi)

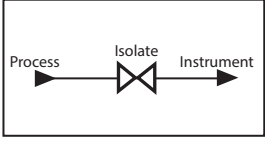

APPLICATION

High Integrity instrument isolation of pressure gauges and pressure transmitters.
Only available in 316SS or Carbon Steel (with Plated option).
(See HOW TO ORDER Data Sheet).



Weight = 2.4 lbs (1.1 kg)

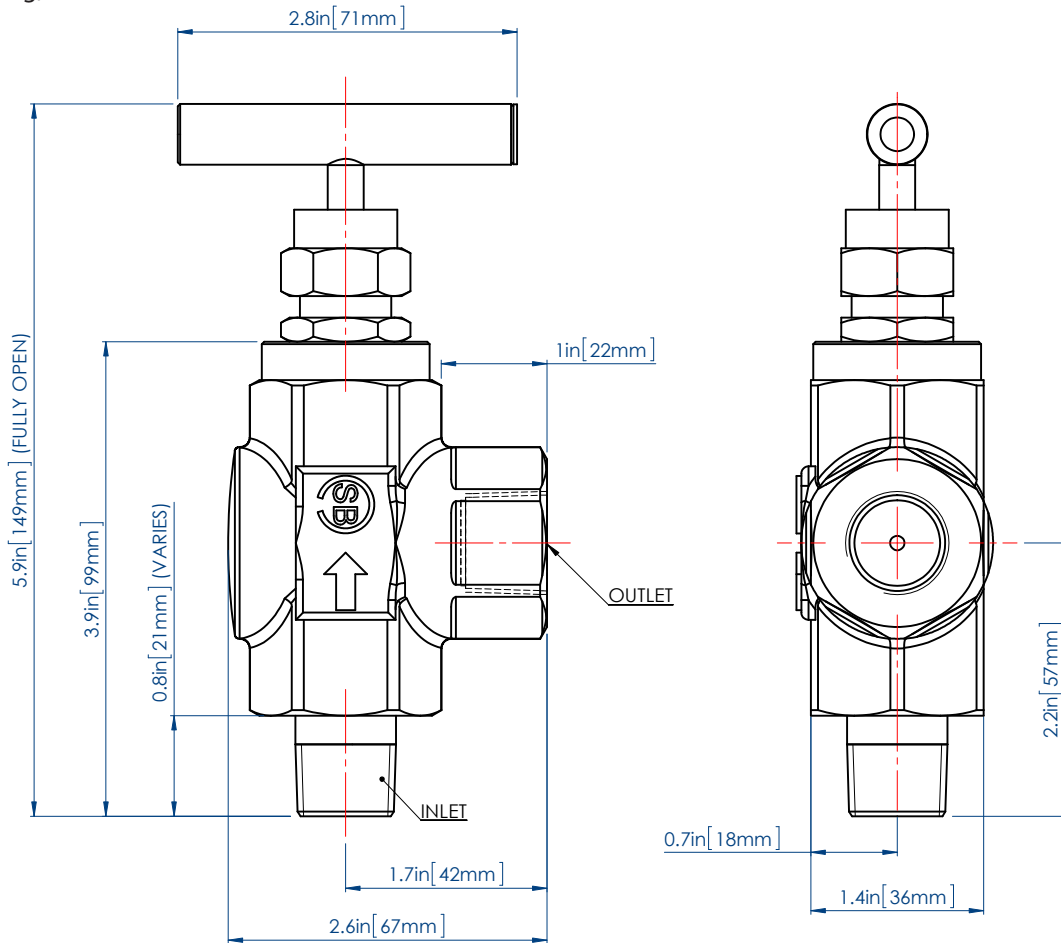

Dimensions shown in inches & mm

Stewarts - USA, LLC

6786 Tipperary, Houston, Texas 77061 USA
info@stewartusa.com

DATA SHEET REF: D1-REV01-15 SUS A

Phone: 713.643.1022. Fax: 713.643.2855. Toll Free: 800.901.1316

Web: www.STEWARTSUSA.com



MODEL - E1



SINGLE BLOCK (In line with Vent Plug) HAND VALVE 413 bar (6000 psi)

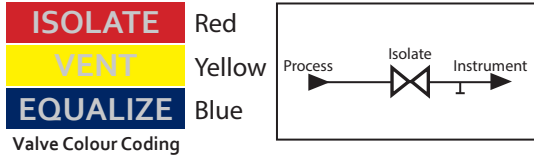

APPLICATION

High Integrity instrument isolation of pressure gauges and pressure transmitters.
Also available in a range of other materials and options
(See HOW TO ORDER Data Sheet).

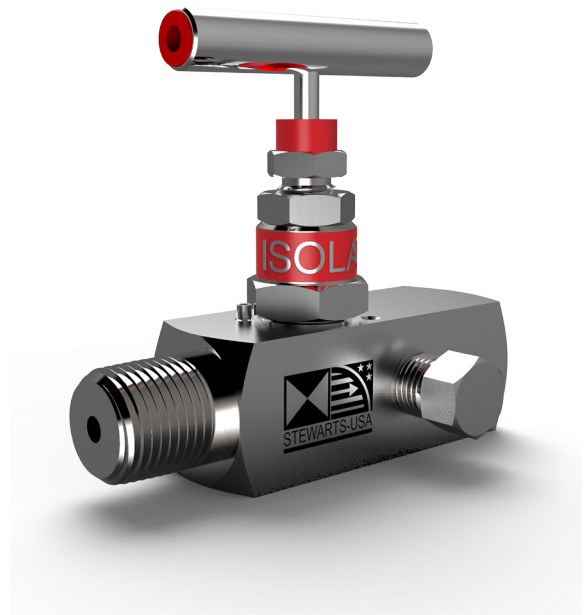

Weight = 1.3 Pounds (0.6 kg)

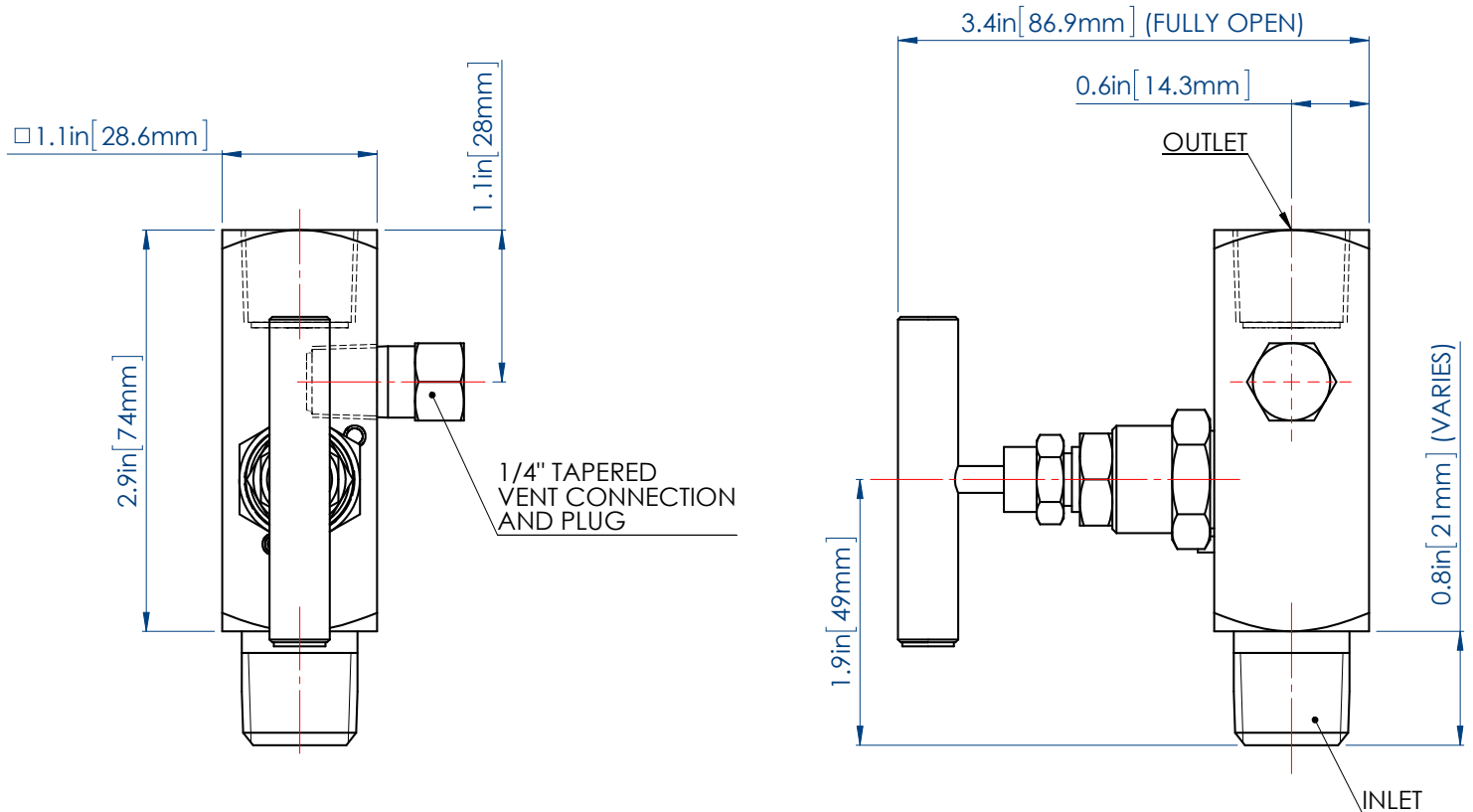

Dimensions shown in mm & inches

Stewarts - USA, LLC

6786 Tipperary, Houston, Texas 77061 USA
info@stewartsusa.com

DATA SHEET REF: E1MF-REV01-15 SUS A

Phone: 713.643.1022. Fax: 713.643.2855. Toll Free: 800.901.1316

Web: www.STEWARTSUSA.com



MODEL - F1

SINGLE BLOCK (In line with Bleed Plug)
HAND VALVE 413 bar (6000 psi)

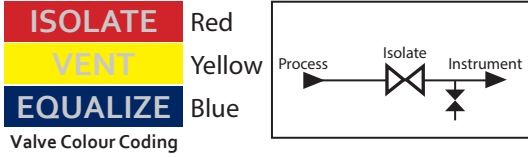

APPLICATION

High Integrity instrument isolation of pressure gauges and pressure transmitters.
Also available in a range of other materials and options
(See HOW TO ORDER Data Sheet).



Weight = 1.3 lbs (0.6 kg)

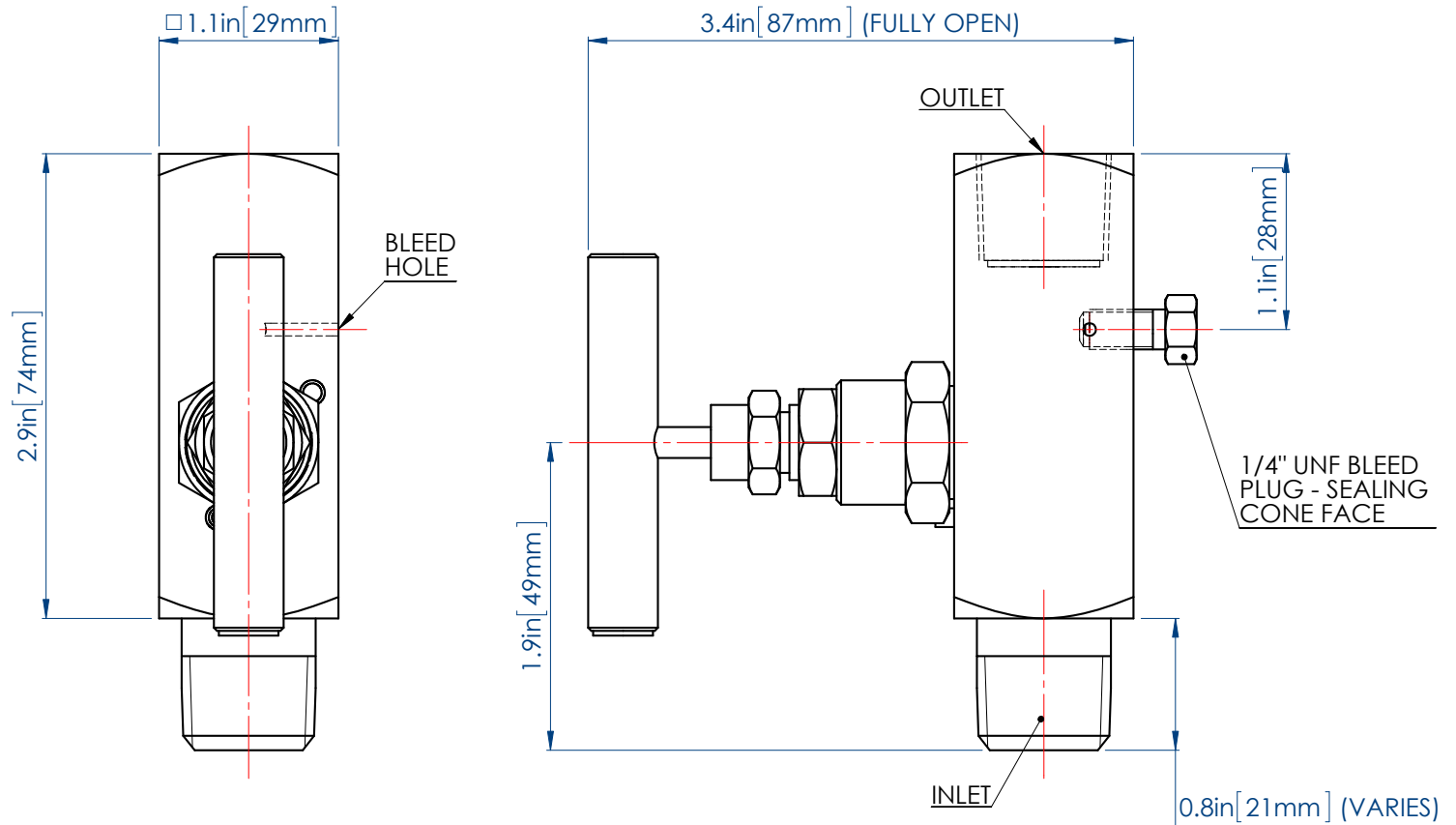

Dimensions shown in inches & mm

Stewarts - USA, LLC

6786 Tipperary, Houston, Texas 77061 USA
info@stewartusa.com

DATA SHEET REF: F1-REV01-15 SUS4

Phone: 713.643.1022. Fax: 713.643.2855. Toll Free: 800.901.1316

Web: www.STEWARTSUSA.com



MODEL - H1



SINGLE BLOCK (In line Gauge Multiport) HAND VALVE 413 bar (6000 psi)

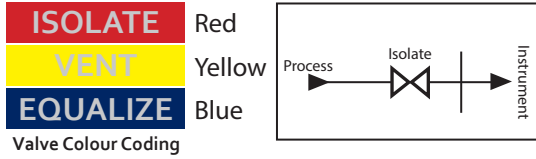

APPLICATION

High Integrity instrument isolation of pressure gauges and pressure transmitters.
Also available in a range of other materials and options
(See HOW TO ORDER Data Sheet).



Weight = 1.5 Pounds (0.7 kg)

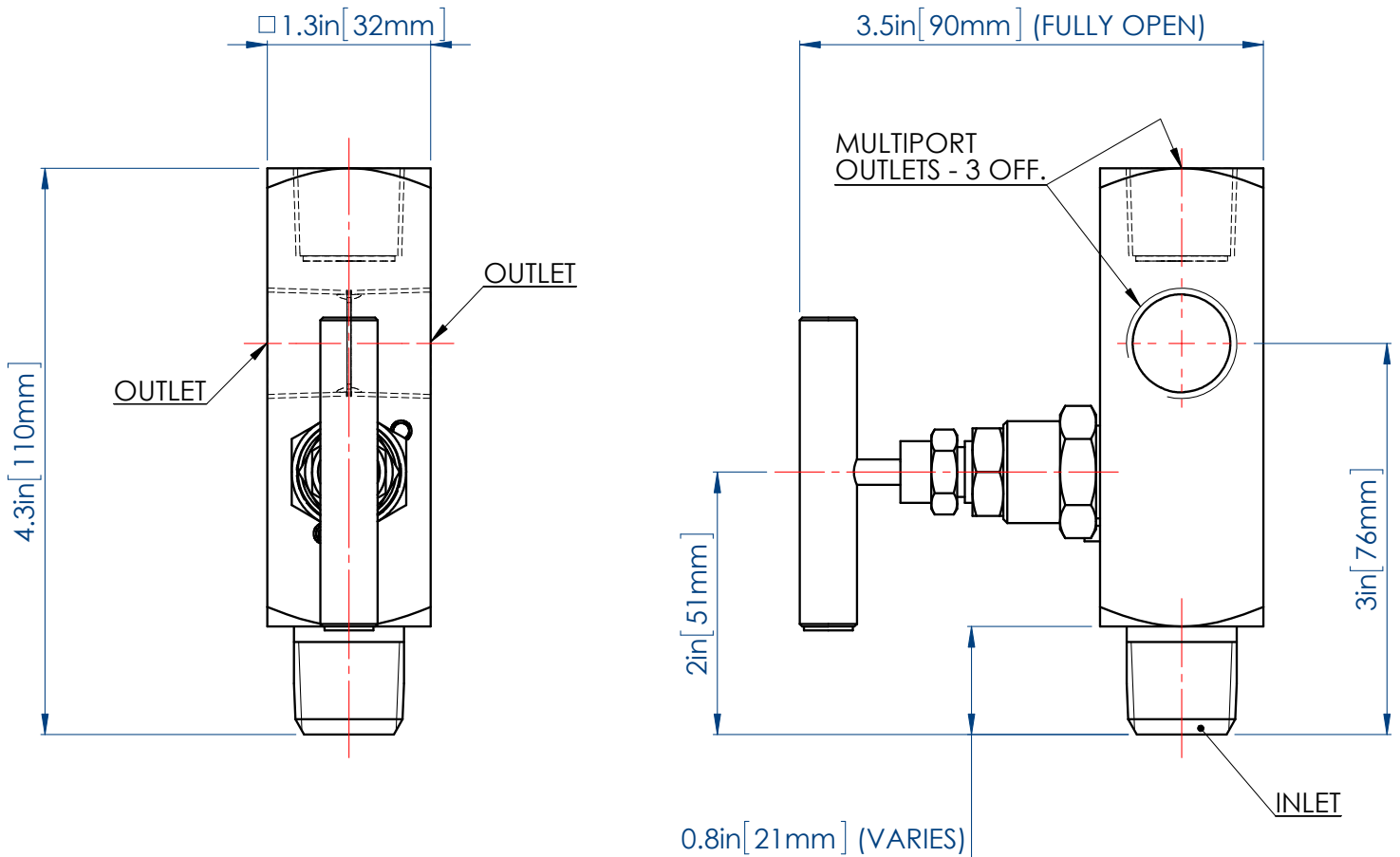

Dimensions shown in mm & inches

Stewarts - USA, LLC

6786 Tipperary, Houston, Texas 77061 USA
info@stewartsusa.com

DATA SHEET REF: H1MF-REV01-15 SUSA

Phone: 713.643.1022. Fax: 713.643.2855. Toll Free: 800.901.1316

Web: www.STEWARTSUSA.com



NOTES



Stewarts - USA, LLC

6786 Tipperary, Houston, Texas 77061 USA
info@stewartsusa.com

DATA SHEET REF: NOTES -REV01-15 SUSAA

Phone: 713.643.1022. Fax: 713.643.2855. Toll Free: 800.901.1316

Web: www.STEWARTSUSA.com

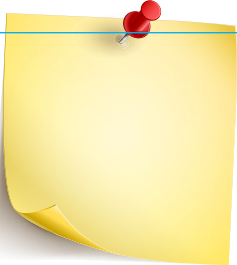

2 - VALVE MANIFOLDS



STEWARTS 2-Valve manifolds are used in instances where it is necessary to relieve the pressure in the downstream when isolating an instrument or part of a system. Stewarts manufacture these manifolds in various mounting styles with a wide range of connection options. Depending on the fluid medium and environmental factors, STEWARTS 2-valve manifolds are the ideal solution giving reliability, improved safety performance and cost reduction.



Disclaimer:- Process pipework and structure in the above is for illustration purposes only; it does not reflect full requirement of a system installation and additional parts may be necessary.

Stewarts - USA, LLC

6786 Tipperary, Houston, Texas 77061 USA
info@stewartusa.com

DATA SHEET REF: 2 DIVIDER-REV01-15 SUSA

Phone: 713.643.1022. Fax: 713.643.2855. Toll Free: 800.901.1316

Web: www.STEWARTSUSA.com



MODEL - J2

REMOTE MOUNT BLOCK AND BLEED (Female / Female) TWO VALVE MANIFOLD 413 bar (6000 psi)



ISOLATE	Red
VENT	Yellow
EQUALIZE	Blue

Valve Colour Coding

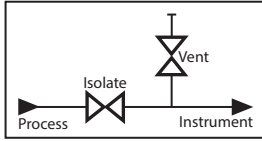

APPLICATION

Using The 2-Valve Manifold

In normal operation the "isolate" valve is open while the "vent" valve is closed. To remove the instrument, first close the "isolate" valve, then open the "vent" valve to relieve pressure upstream of the "isolate" valve.

Calibration Options

By connecting a calibration gauge to the vent port, it is possible to check the calibration of the instrument without removing it from the installation.

Also available in a range of other materials and options
(See HOW TO ORDER Data Sheet)

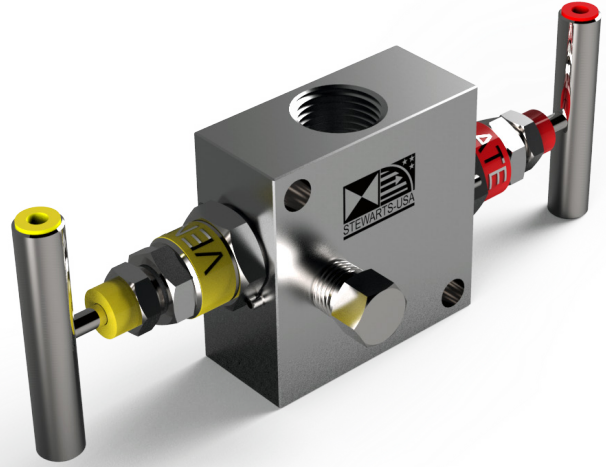

Weight = 2.2 lbs (1 kg)

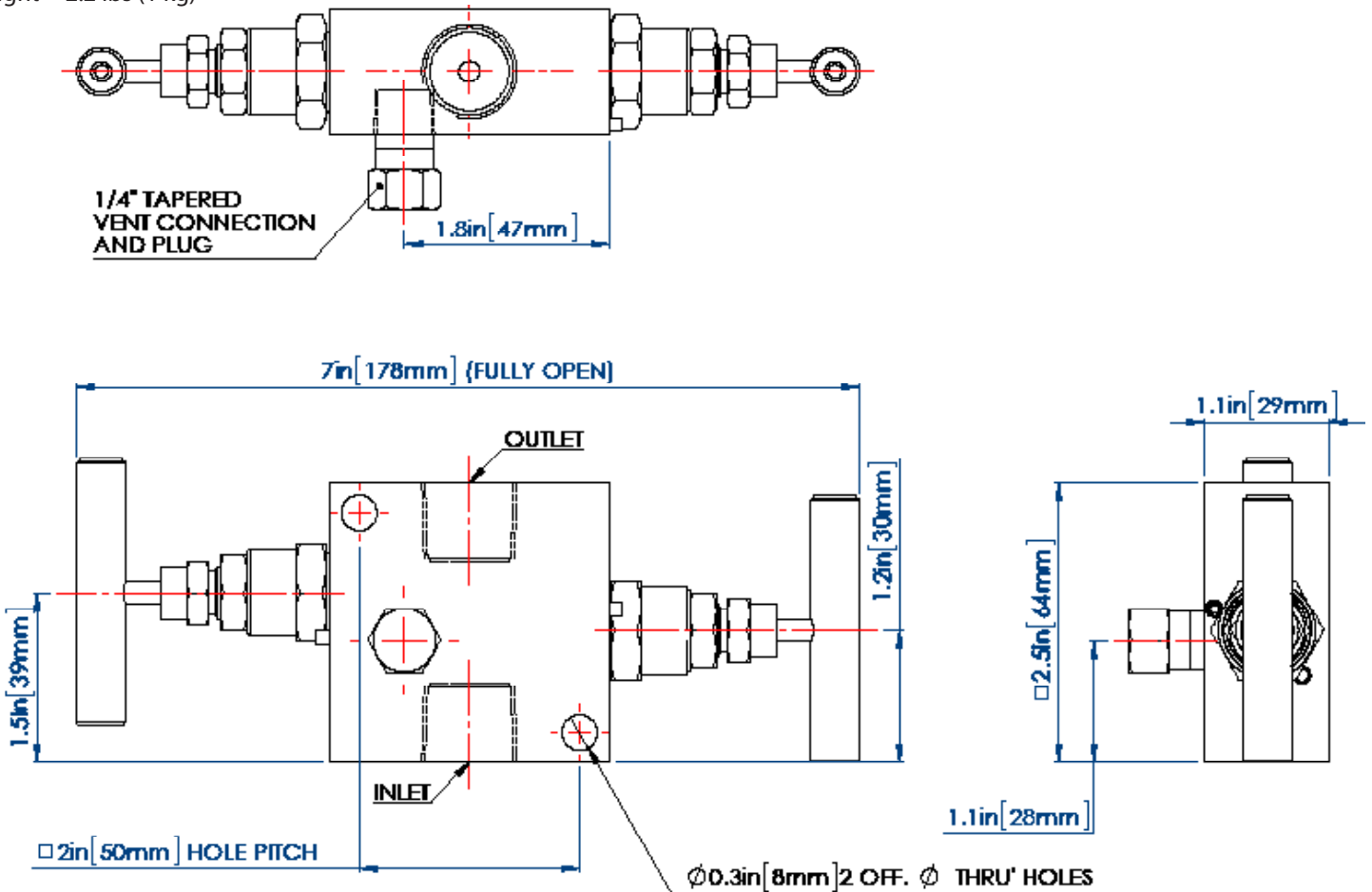

Dimensions shown in inches & mm

Stewarts - USA, LLC

6786 Tipperary, Houston, Texas 77061 USA
info@stewartsusa.com

DATA SHEET REF: J2-REV01-15 SUS A

Phone: 713.643.1022. Fax: 713.643.2855. Toll Free: 800.901.1316

Web: www.STEWARTSUSA.com



MODEL - K2

REMOTE MOUNT BLOCK AND BLEED (Angled Bonnet) TWO VALVE MANIFOLD 413 bar (6000 psi)



ISOLATE	Red
VENT	Yellow
EQUALIZE	Blue

Valve Colour Coding

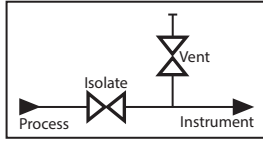

APPLICATION

Using The 2-Valve Manifold

In normal operation the "isolate" valve is open while the "vent" valve is closed. To remove the instrument, first close the "isolate" valve, then open the "vent" valve to relieve pressure upstream of the "isolate" valve.

Calibration Options

By connecting a calibration gauge to the vent port, it is possible to check the calibration of the instrument without removing it from the installation.

Also available in a range of other materials and options (See HOW TO ORDER Data Sheet)



Weight = 1.8 lbs (0.8 kg)

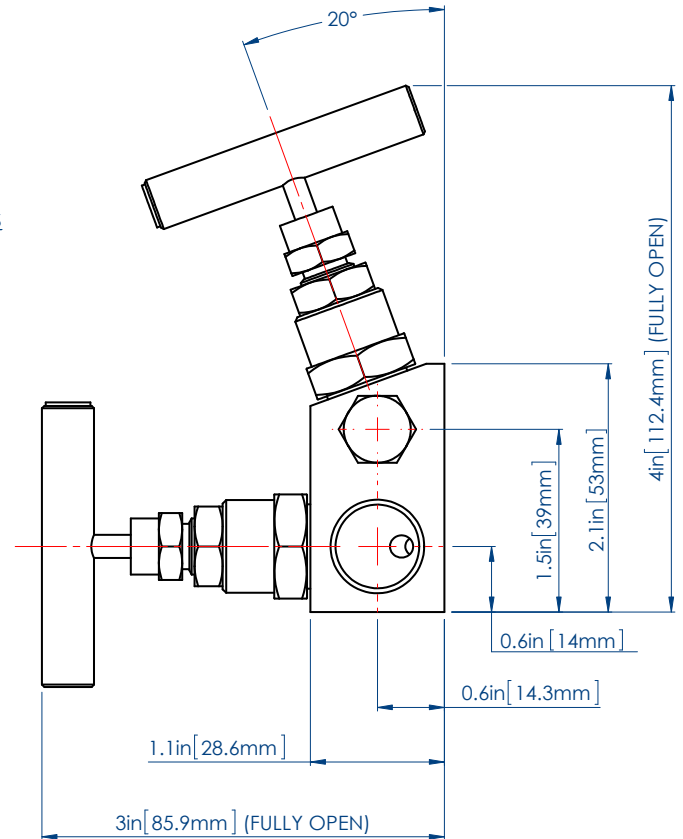
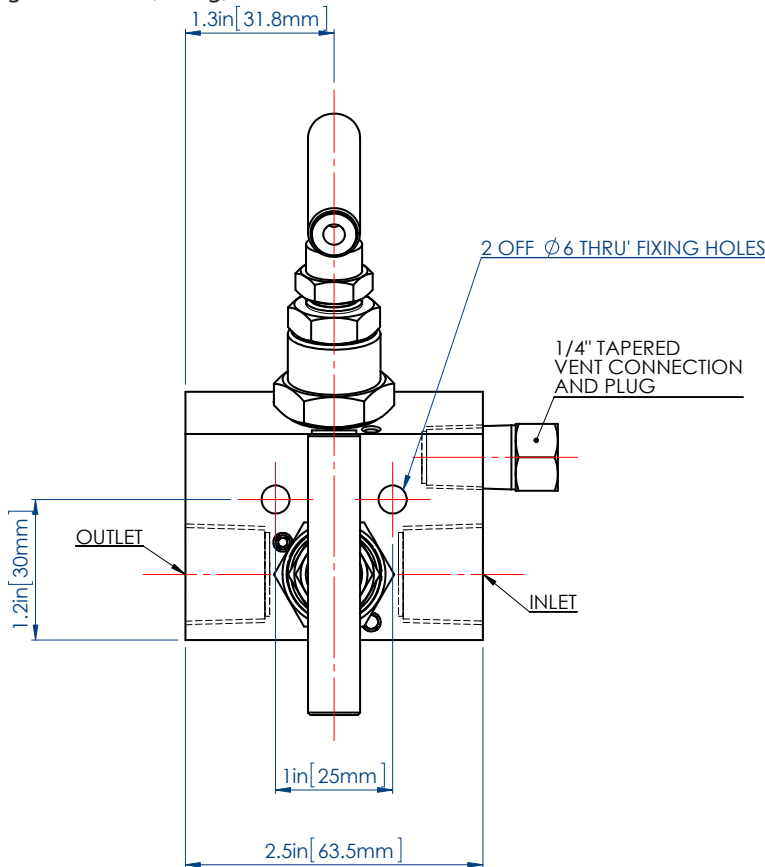

Dimensions shown in inches & mm

Stewarts - USA, LLC

6786 Tipperary, Houston, Texas 77061 USA
info@stewartusa.com

DATA SHEET REF: K2-REV01-15 SUS316

Phone: 713.643.1022. Fax: 713.643.2855. Toll Free: 800.901.1316

Web: www.STEWARTSUSA.com



MODEL - L2

REMOTE MOUNT BLOCK AND BLEED TWO VALVE MANIFOLD 413 bar (6000 psi)



ISOLATE	Red
VENT	Yellow
EQUALIZE	Blue

Valve Colour Coding

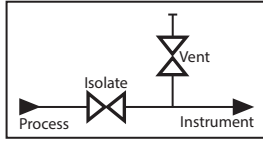

APPLICATION

Using The 2-Valve Manifold

In normal operation the "isolate" valve is open while the "vent" valve is closed. To remove the instrument, first close the "isolate" valve, then open the "vent" valve to relieve pressure upstream of the "isolate" valve.

Calibration Options

By connecting a calibration gauge to the vent port, it is possible to check the calibration of the instrument without removing it from the installation.

Also available in a range of other materials and options
(See HOW TO ORDER Data Sheet)

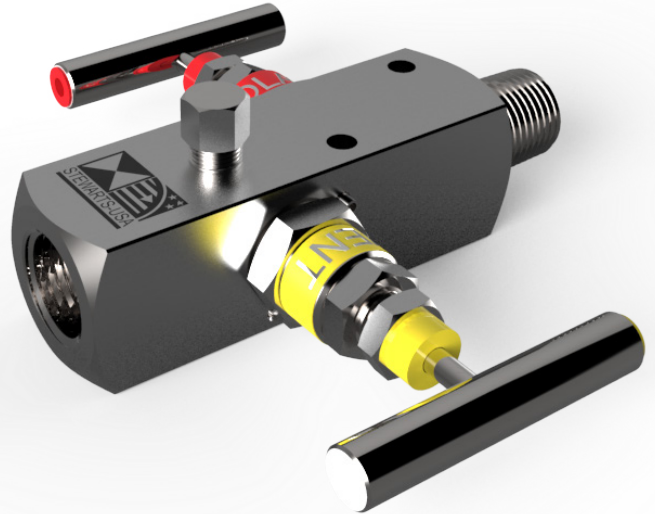

Weight = 2.2 lbs (1 kg)

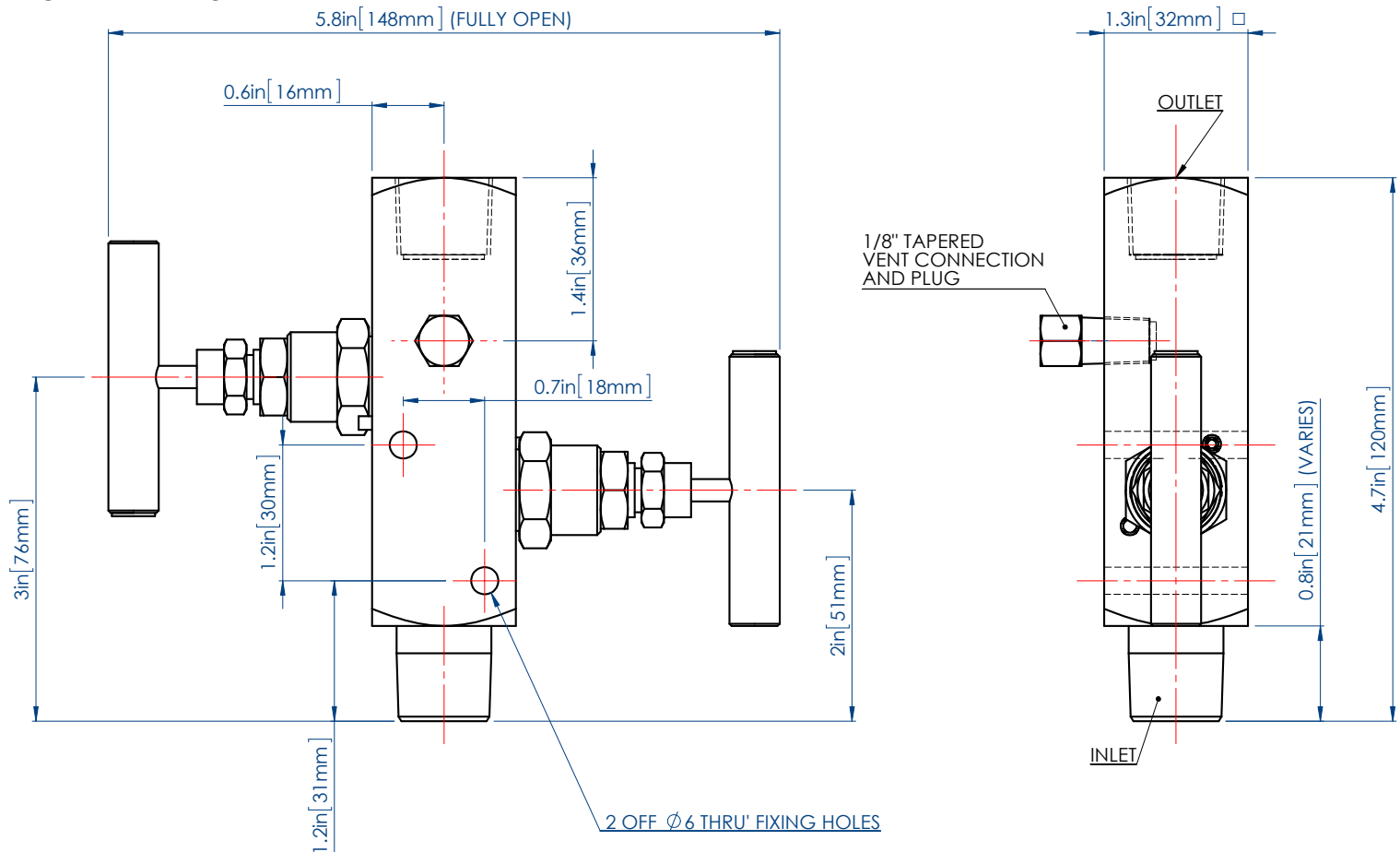

Dimensions shown in inches & mm

Stewarts - USA, LLC

6786 Tipperary, Houston, Texas 77061 USA
info@stewartusa.com

DATA SHEET REF: L2-REV01-15 SUS A

Phone: 713.643.1022. Fax: 713.643.2855. Toll Free: 800.901.1316

Web: www.STEWARTSUSA.com



MODEL - M2

DIRECT MOUNT BLOCK AND BLEED (Pipe to Flange) TWO VALVE MANIFOLD 413 bar (6000 psi)



ISOLATE	Red
VENT	Yellow
EQUALIZE	Blue

Valve Colour Coding

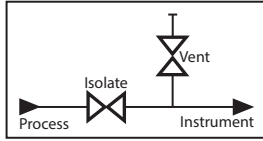

APPLICATION

Using The 2-Valve Manifold

In normal operation the "isolate" valve is open while the "vent" valve is closed. To remove the instrument, first close the "isolate" valve, then open the "vent" valve to relieve pressure upstream of the "isolate" valve.

Calibration Options

By connecting a calibration gauge to the vent port, it is possible to check the calibration of the instrument without removing it from the installation.

Also available in a range of other materials and options
(See HOW TO ORDER Data Sheet)

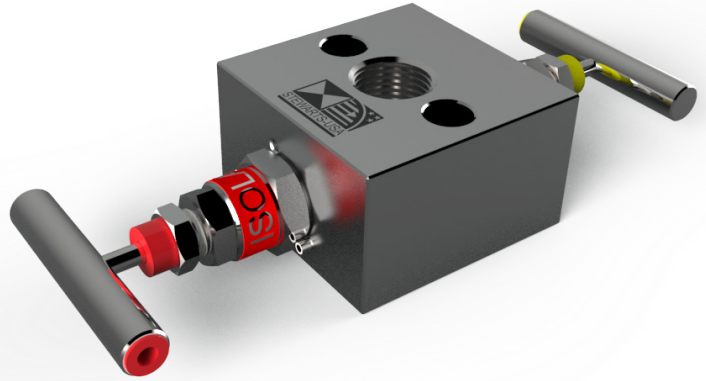

Weight = 2.9 lbs (1.3 kg)

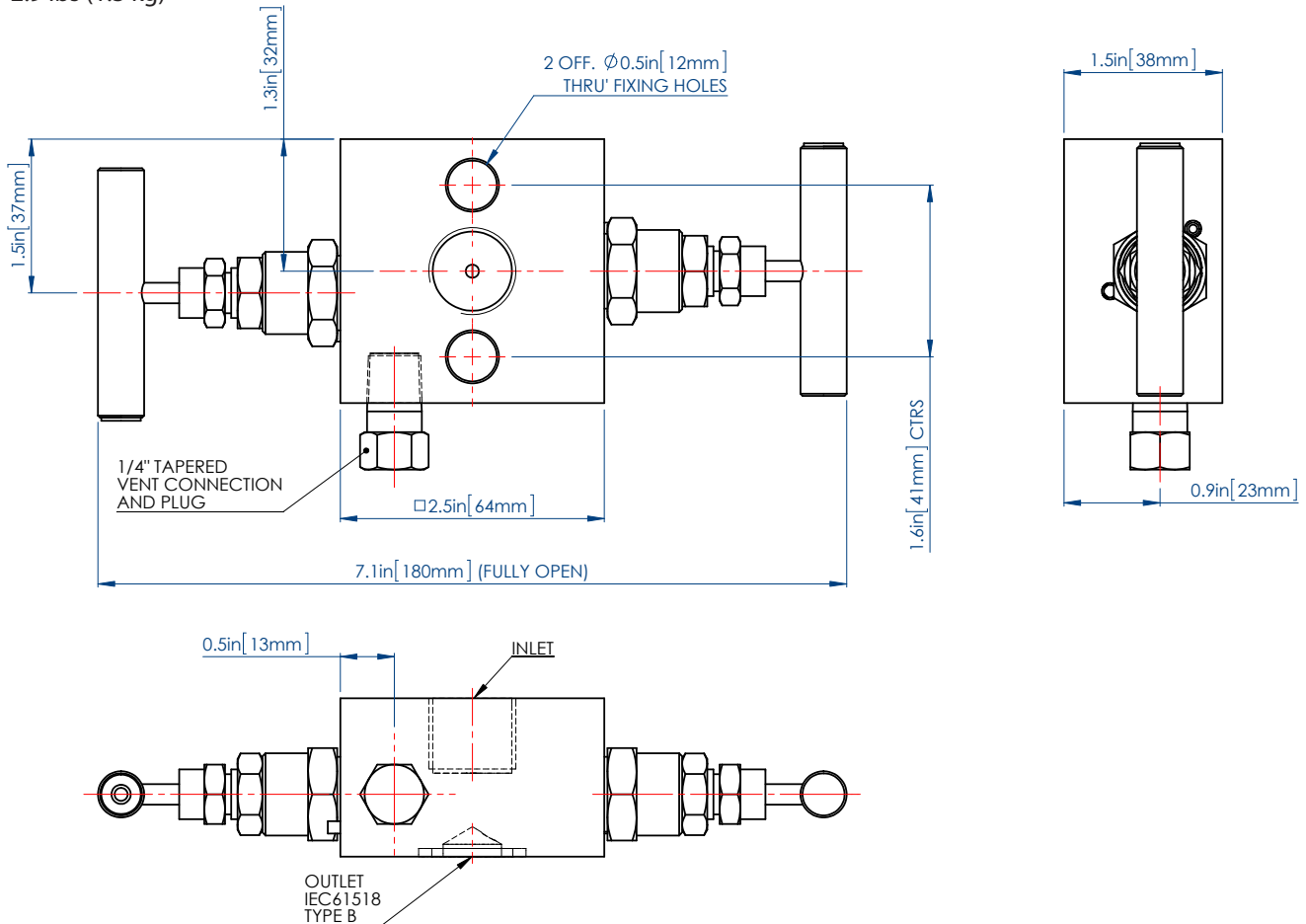

Dimensions shown in inches & mm

Stewarts - USA, LLC

6786 Tipperary, Houston, Texas 77061 USA
info@stewartusa.com

DATA SHEET REF: M2-REV01-15 SUSA

Phone: 713.643.1022. Fax: 713.643.2855. Toll Free: 800.901.1316

Web: www.STEWARTSUSA.com



MODEL - N2

DIRECT MOUNT BLOCK AND BLEED (Enclosure Pipe to Flange) TWO VALVE MANIFOLD 413 bar (6000 psi)



ISOLATE	Red
VENT	Yellow
EQUALIZE	Blue

Valve Colour Coding

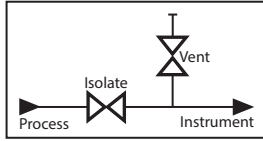

APPLICATION

Using The 2-Valve Manifold

In normal operation the "isolate" valve is open while the "vent" valve is closed. To remove the instrument, first close the "isolate" valve, then open the "vent" valve to relieve pressure upstream of the "isolate" valve.

Calibration Options

By connecting a calibration gauge to the vent port, it is possible to check the calibration of the instrument without removing it from the installation.

Also available in a range of other materials and options
(See HOW TO ORDER Data Sheet)



Weight = 6.2 lbs (2.8 kg)

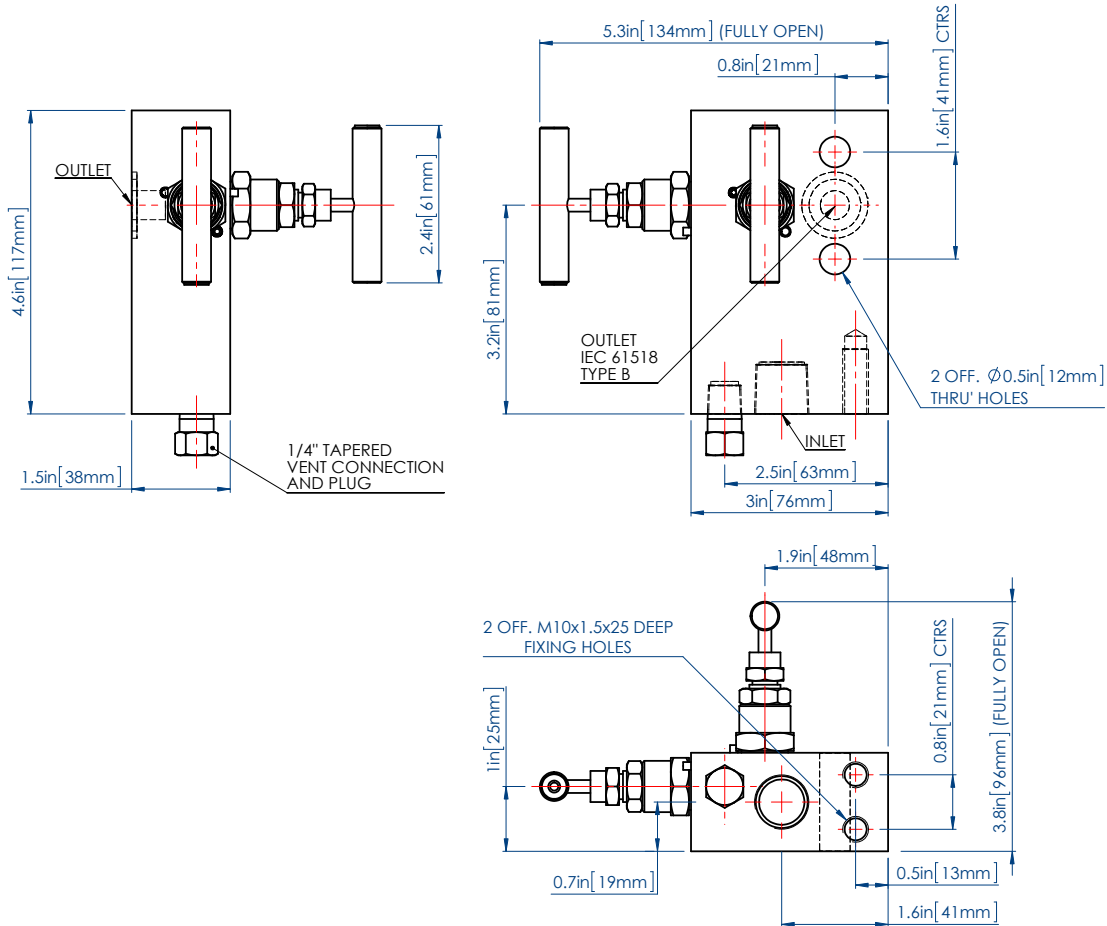

Dimensions shown in inches & mm

Stewarts - USA, LLC

6786 Tipperary, Houston, Texas 77061 USA
info@stewartusa.com

DATA SHEET REF: N2-REV01-15 SUS4

Phone: 713.643.1022. Fax: 713.643.2855. Toll Free: 800.901.1316

Web: www.STEWARTSUSA.com



MODEL - 02

REMOTE MOUNT BLOCK AND BLEED (Flat Face) TWO VALVE MANIFOLD 413 bar (6000 psi)



ISOLATE	Red
VENT	Yellow
EQUALIZE	Blue

Valve Colour Coding

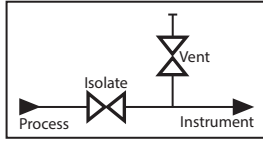

APPLICATION

Using The 2-Valve Manifold

In normal operation the "isolate" valve is open while the "vent" valve is closed. To remove the instrument, first close the "isolate" valve, then open the "vent" valve to relieve pressure upstream of the "isolate" valve.

Calibration Options

By connecting a calibration gauge to the vent port, it is possible to check the calibration of the instrument without removing it from the installation.

Also available in a range of other materials and options
(See HOW TO ORDER Data Sheet)

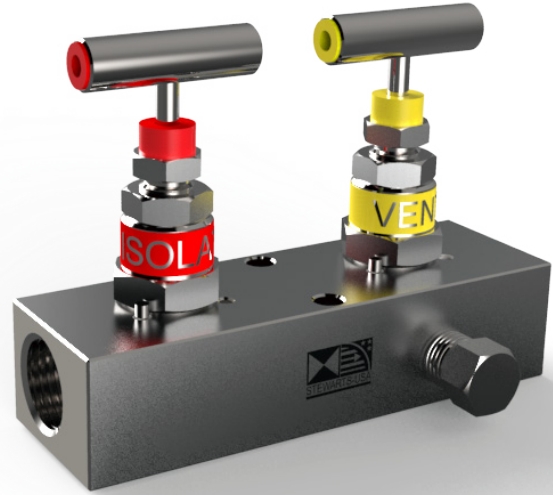

Weight = 2.4 lbs (1.1 kg)

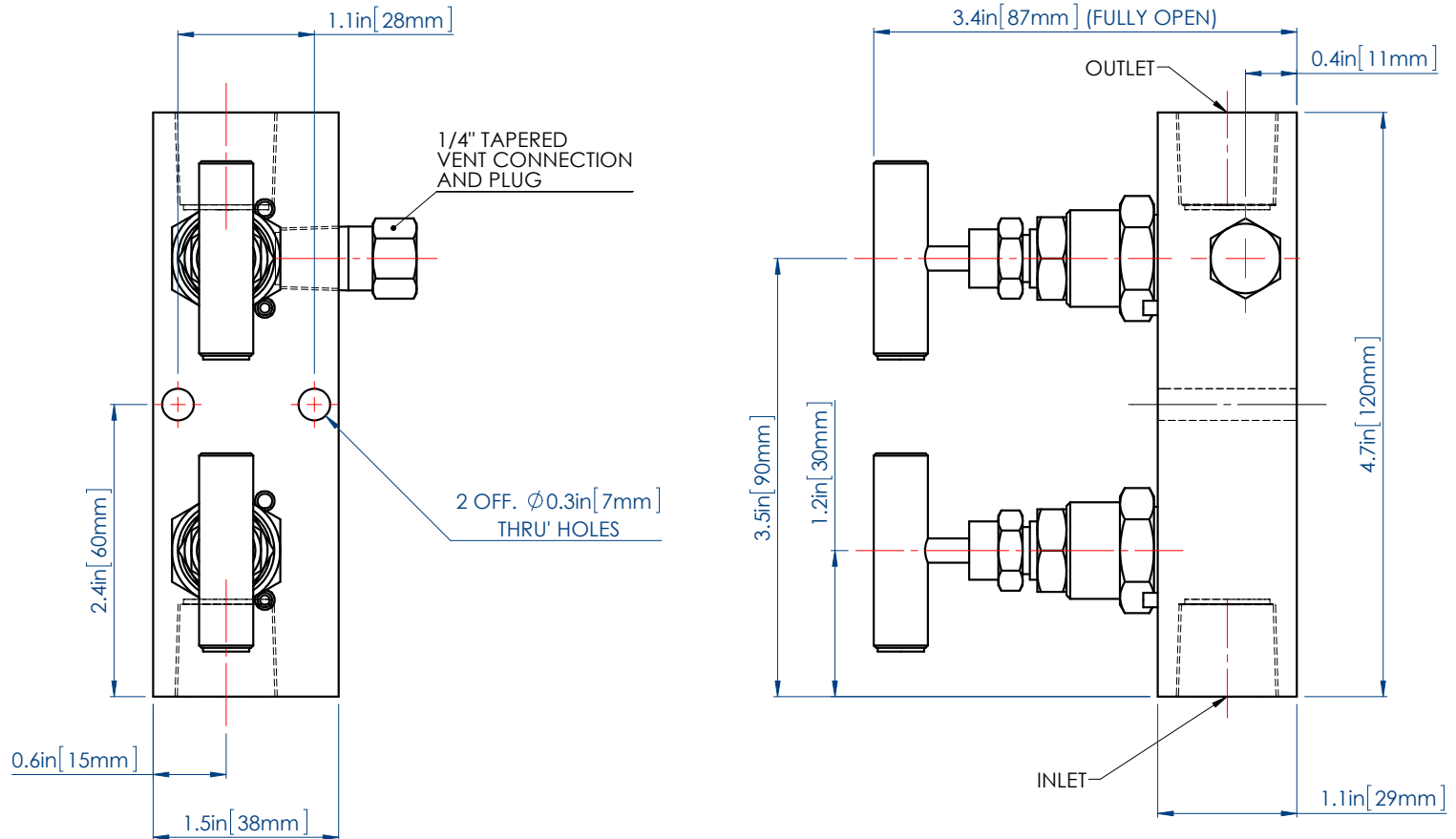

Dimensions shown in inches & mm

Stewarts - USA, LLC

6786 Tipperary, Houston, Texas 77061 USA
info@stewartusa.com

DATA SHEET REF: O2-REV01-15 SUS316

Phone: 713.643.1022. Fax: 713.643.2855. Toll Free: 800.901.1316

Web: www.STEWARTSUSA.com



MODEL - Q2

DIRECT MOUNT BLOCK AND BLEED (Transmitter Manifold) TWO VALVE MANIFOLD 413 bar (6000 psi)



ISOLATE	Red
VENT	Yellow
EQUALIZE	Blue

Valve Colour Coding

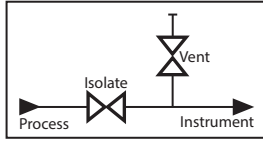

APPLICATION

Using The 2-Valve Manifold

In normal operation the "isolate" valve is open while the "vent" valve is closed. To remove the instrument, first close the "isolate" valve, then open the "vent" valve to relieve pressure upstream of the "isolate" valve.

Calibration Options

By connecting a calibration gauge to the vent port, it is possible to check the calibration of the instrument without removing it from the installation.

Also available in a range of other materials and options
(See HOW TO ORDER Data Sheet)

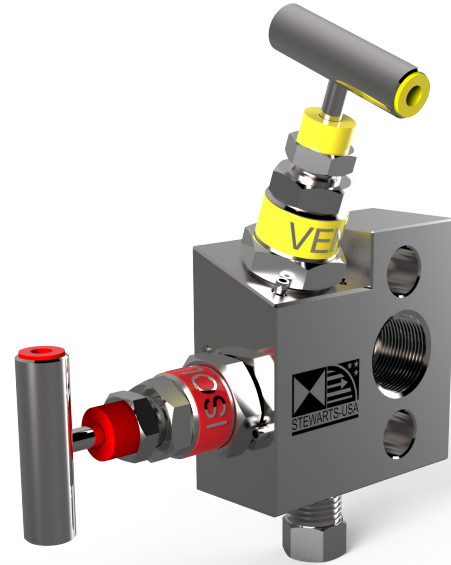

Weight = 2.2 lbs (1 kg)

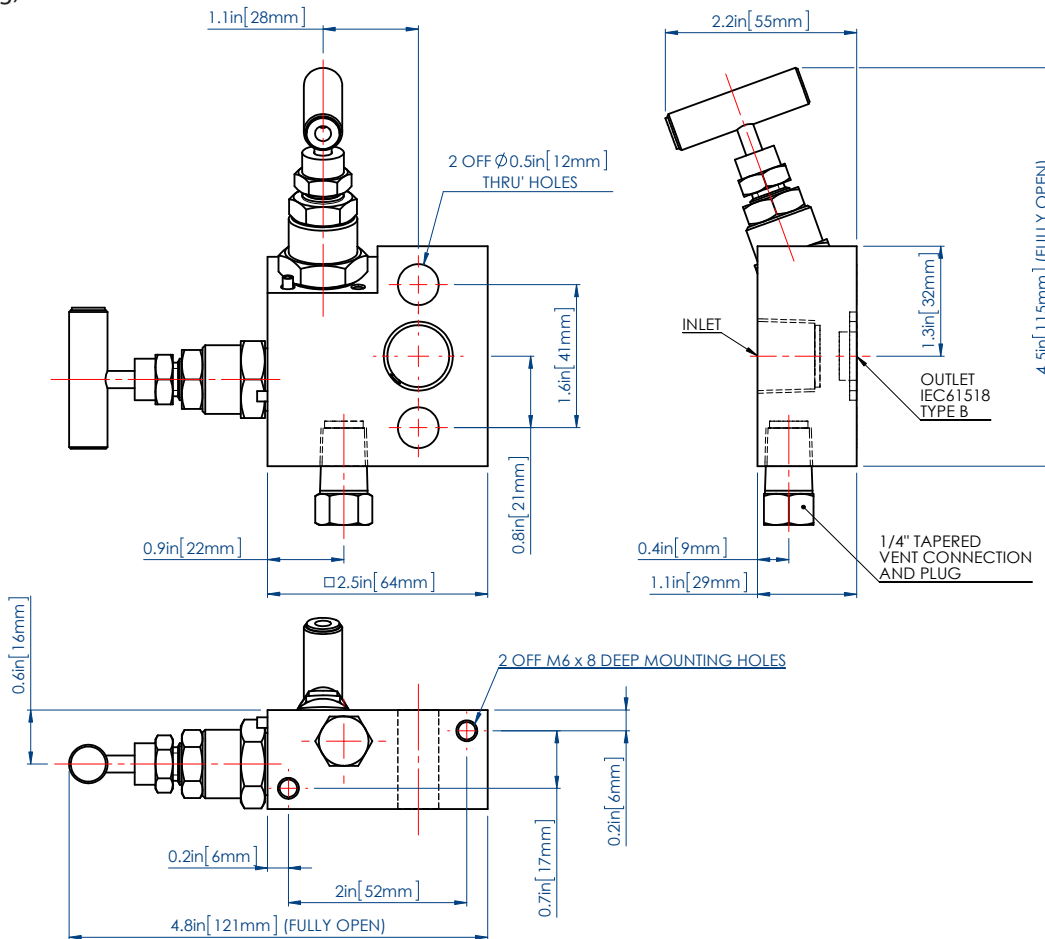

Dimensions shown in inches & mm

Stewarts - USA, LLC

6786 Tipperary, Houston, Texas 77061 USA
info@stewartusa.com

DATA SHEET REF: Q2-REV01-15 SUS A

Phone: 713.643.1022. Fax: 713.643.2855. Toll Free: 800.901.1316

Web: www.STEWARTSUSA.com



3 - VALVE MANIFOLDS



STEWARTS 3-Valve manifolds are precision machined in 3 basic design configurations:- For single line flow, the double block bleed (DBB) manifolds provide maximum safety and reliability for more hazardous situations. For differential dual line flow is the single block and equalise; ideal for calibrating and zero-ing differential measurement instruments or for other isolation and equalisation of system sections. Also, for differential flow, is the single block and equalise with vent plug connections; these provide a means to relieve downstream pressure on either side after isolation. Used again for zero-ing and calibration functions and ideal for performing various maintenance, testing and sampling functions with a high level of safety and reliability.

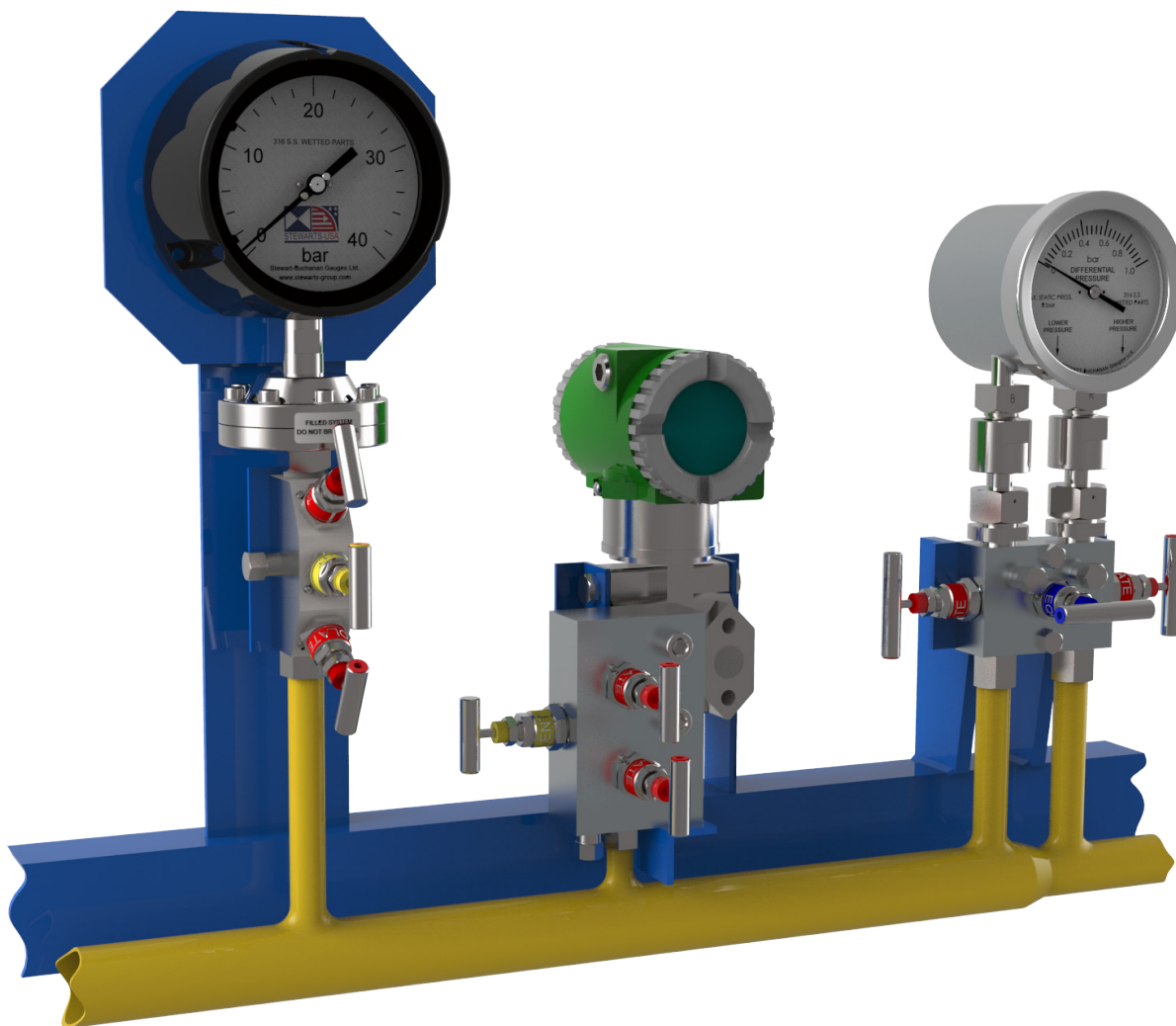

Disclaimer:- Process pipework and structure in the above is for illustration purposes only; it does not reflect full requirement of a system installation and additional parts may be necessary.

Stewarts - USA, LLC

6786 Tipperary, Houston, Texas 77061 USA
info@stewartusa.com

DATA SHEET REF: 3 DIVIDER-REV01-15 SUS A

Phone: 713.643.1022. Fax: 713.643.2855. Toll Free: 800.901.1316

Web: www.STEWARTSUSA.com



MODEL - K3

DOUBLE BLOCK AND BLEED VALVE (Angled Bonnet) THREE VALVE MANIFOLD 413 bar (6000 psi)



ISOLATE	Red
VENT	Yellow
EQUALIZE	Blue

Valve Colour Coding

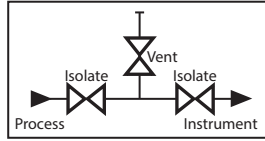

APPLICATION

Using the 3-valve DBB manifold

In normal operation the "isolate" valves are open while the "vent" valve and plug are closed. This provides unobstructed flow to the instrument or other equipment. To isolate the instrument for maintenance and/or removal, first close the "primary" upstream valve. Next open the "vent" valve to relieve the trapped pressure and if necessary use the vent plug to drain off excess fluid. Close the secondary "isolate" downstream valve, this acts as a safety back up, then close the "vent" valve and plug. The instrument or other equipment can now be safely removed and maintenance carried out. Both flow paths to the exterior of the system through the manifold have been double blocked for safety.

Calibration and other options

It is possible to connect a test gauge set up to the vent plug connection in order to calibrate the instrument without removing it from the system. With use of the "vent" valve and plug it may also be possible to carry out system bleed, sampling and injection operations.

Also available in a range of other materials and options

(See HOW TO ORDER Data Sheet).

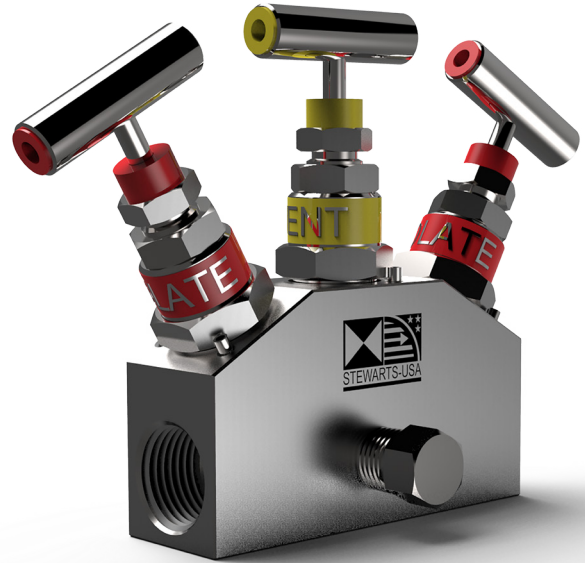

Weight = 2.6 Pounds (1.2 kg)

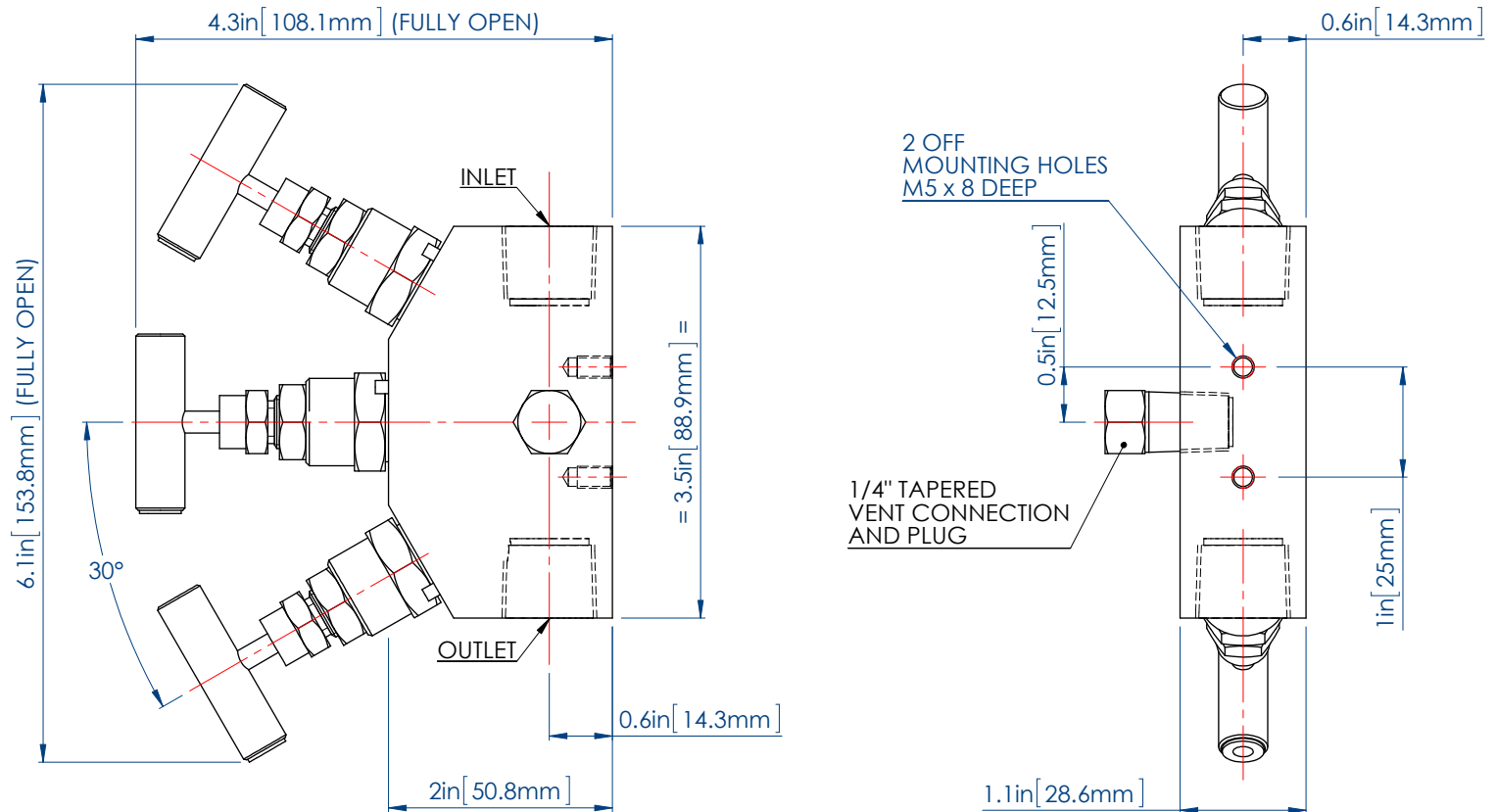

Dimensions shown in inches & mm

Stewarts - USA, LLC

6786 Tipperary, Houston, Texas 77061 USA
info@stewartusa.com

DATA SHEET REF: K3-REV01-15 SUSA

Phone: 713.643.1022. Fax: 713.643.2855. Toll Free: 800.901.1316

Web: www.STEWARTSUSA.com



MODEL - L3

DOUBLE BLOCK AND BLEED VALVE THREE VALVE MANIFOLD 413 bar (6000 psi)



ISOLATE	Red
VENT	Yellow
EQUALIZE	Blue

Valve Colour Coding

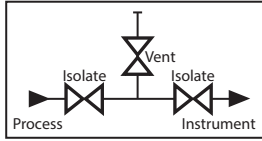

APPLICATION

Using the 3-valve DBB manifold

In normal operation the "isolate" valves are open while the "vent" valve and plug are closed. This provides unobstructed flow to the instrument or other equipment. To isolate the instrument for maintenance and/or removal, first close the "primary" upstream valve. Next open the "vent" valve to relieve the trapped pressure and if necessary use the vent plug to drain off excess fluid. Close the secondary "isolate" downstream valve, this acts as a safety back up, then close the "vent" valve and plug. The instrument or other equipment can now be safely removed and maintenance carried out. Both flow paths to the exterior of the system through the manifold have been double blocked for safety.

Calibration and other options

It is possible to connect a test gauge set up to the vent plug connection in order to calibrate the instrument without removing it from the system. With use of the "vent" valve and plug it may also be possible to carry out system bleed, sampling and injection operations.

Also available in a range of other materials and options

(See HOW TO ORDER Data Sheet).

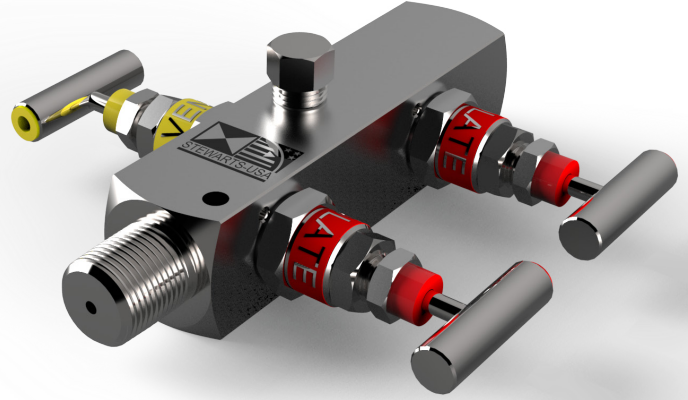

Weight = 2.9 Pounds (1.3 kg)

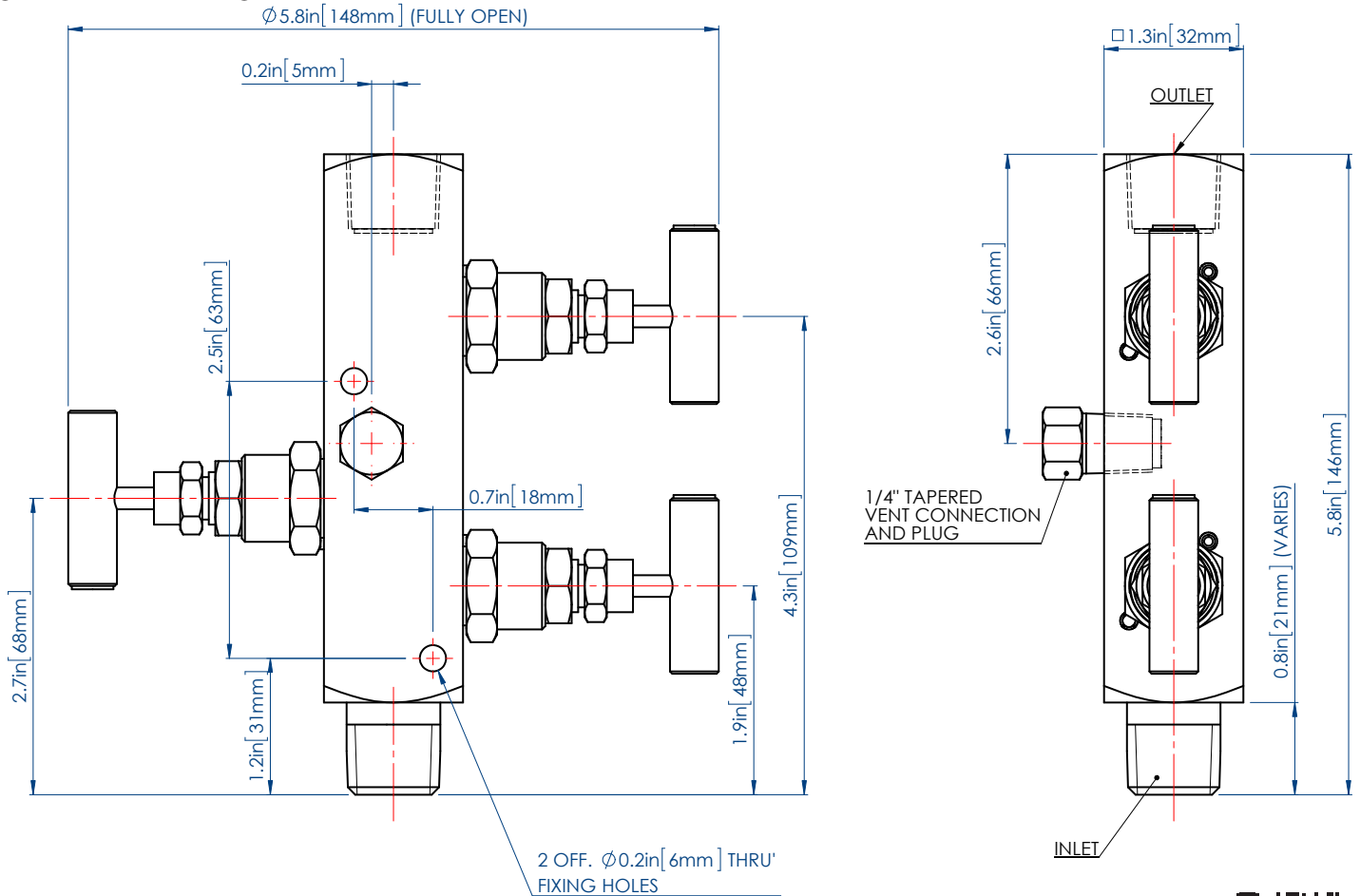

Dimensions shown in inches & mm

Stewarts - USA, LLC

6786 Tipperary, Houston, Texas 77061 USA
info@stewartusa.com

DATA SHEET REF: L3-REV01-15 SUS4

Phone: 713.643.1022. Fax: 713.643.2855. Toll Free: 800.901.1316

Web: www.STEWARTSUSA.com



MODEL - P3

REMOTE MOUNT THREE VALVE MANIFOLD 413 bar (6000 psi)



ISOLATE	Red
VENT	Yellow
EQUALIZE	Blue

Valve Colour Coding

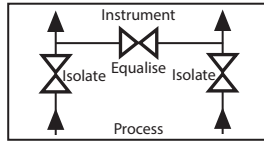

APPLICATION

Using The 3-Valve Manifold

In normal operation the "isolate" valves are open while the "equalize" valve is closed.

This provides a differential pressure reading to the pressure gauge or transmitter. To zero the instrument, first close the downstream "isolate" valve then open the "equalize" valve and adjust the zero setting on the instrument.

Also available in a range of other materials and options (See HOW TO ORDER Data Sheet).



Weight = 3 lbs (1.4 kg) (2.6

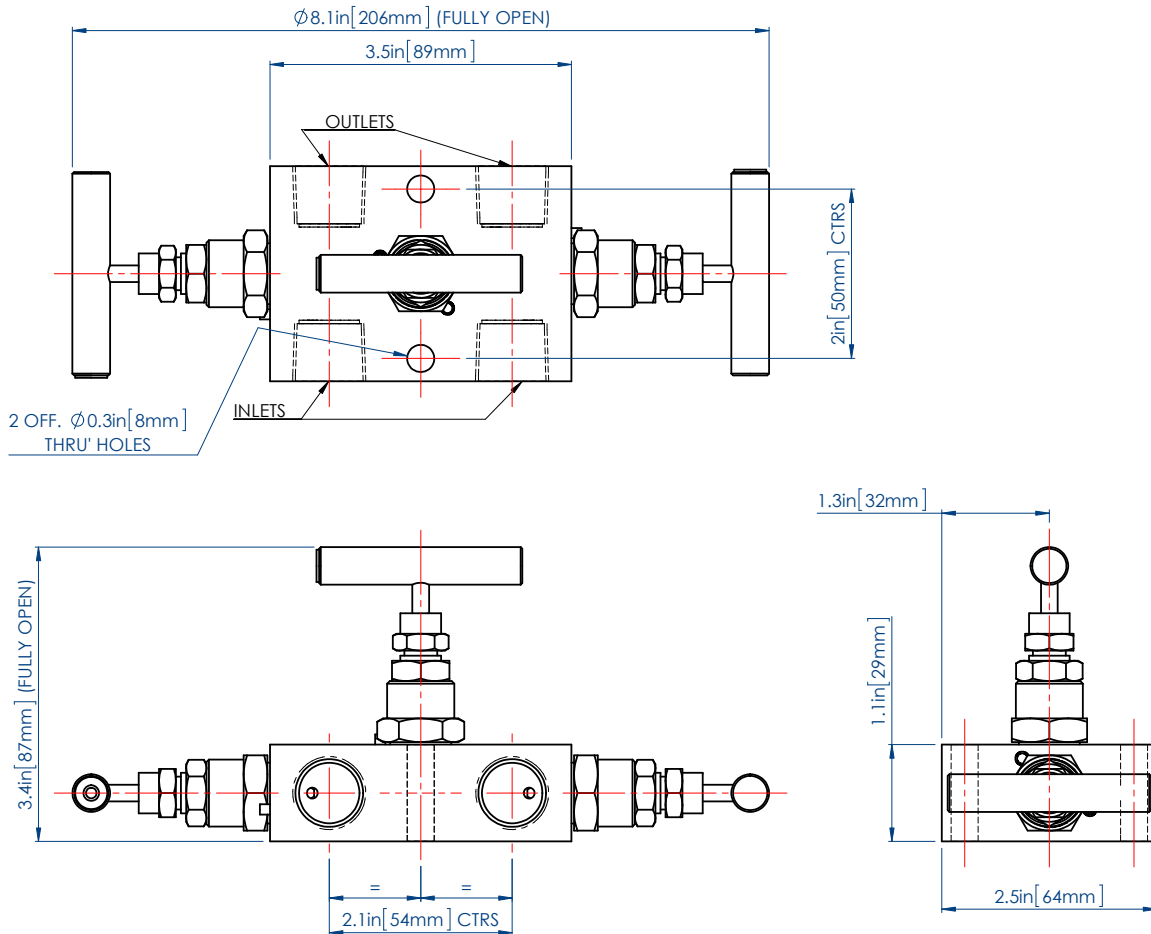

Dimensions shown in inches & mm

Stewarts - USA, LLC

6786 Tipperary, Houston, Texas 77061 USA
info@stewartusa.com

DATA SHEET REF: P3-REV01-15 SUS4

Phone: 713.643.1022. Fax: 713.643.2855. Toll Free: 800.901.1316

Web: www.STEWARTSUSA.com



MODEL - Q3

DIRECT MOUNT (Angled Bonnet) THREE VALVE MANIFOLD 413 bar (6000 psi)



ISOLATE	Red
VENT	Yellow
EQUALIZE	Blue

Valve Colour Coding

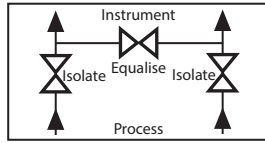

APPLICATION

Using The 3-Valve Manifold

In normal operation the "isolate" valves are open while the "equalize" valve is closed. This provides a differential pressure reading to the pressure gauge or transmitter. To zero the instrument, first close the downstream "isolate" valve then open the "equalize" valve and adjust the zero setting on the instrument. Also available in a range of other materials and options

(See HOW TO ORDER Data Sheet).

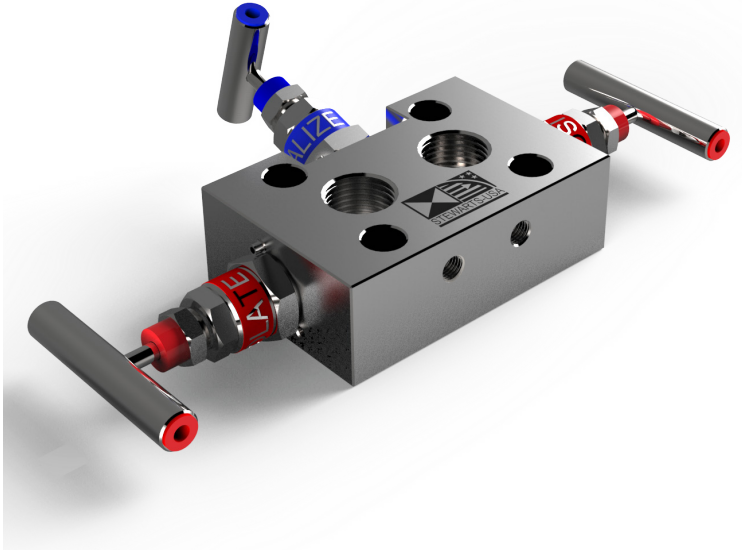

Weight = 3.5 lbs (1.6kg)

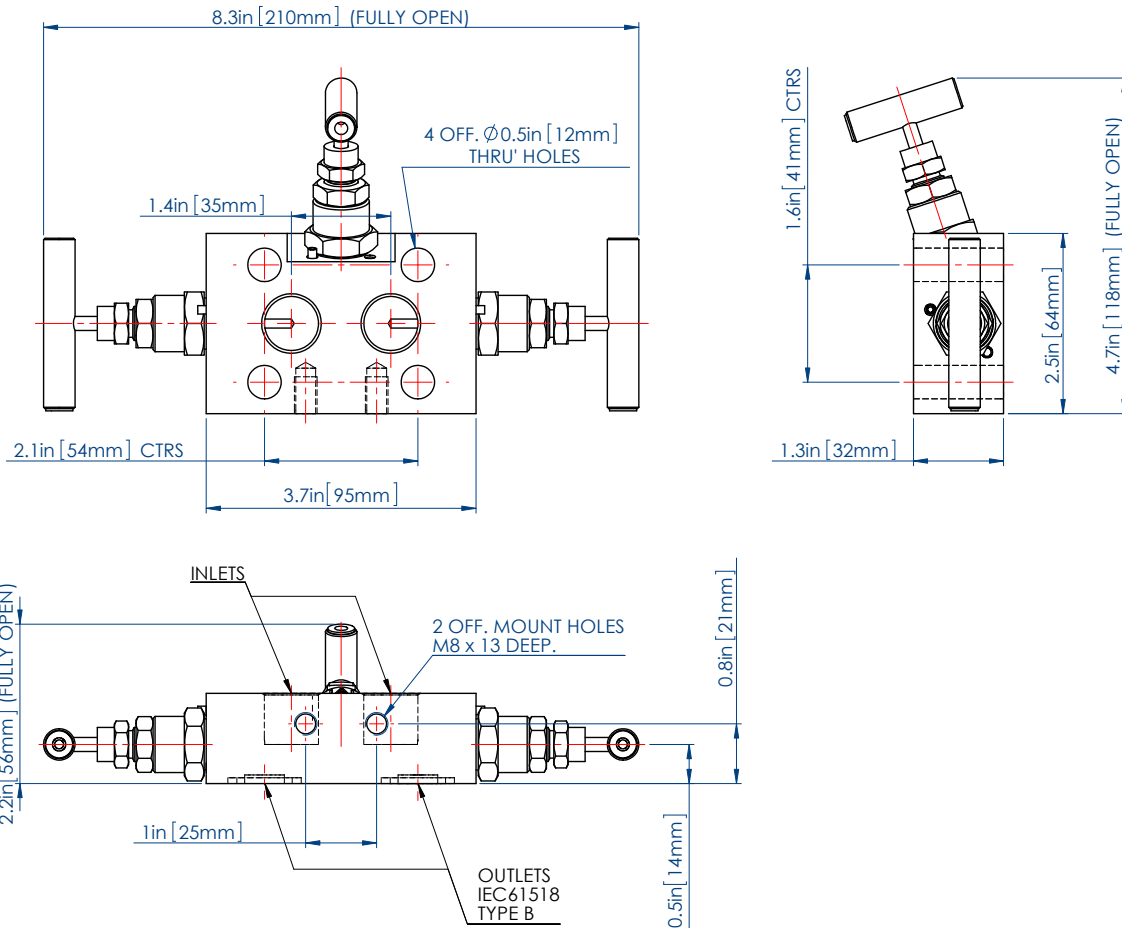

Dimensions shown in inches & mm

Stewarts - USA, LLC

6786 Tipperary, Houston, Texas 77061 USA
info@stewartusa.com

DATA SHEET REF: Q3-REV01-15 SUS A

Phone: 713.643.1022. Fax: 713.643.2855. Toll Free: 800.901.1316

Web: www.STEWARTSUSA.com



MODEL - R3

REMOTE MOUNT (With Vent Plugs) THREE VALVE MANIFOLD 413 bar (6000 psi)

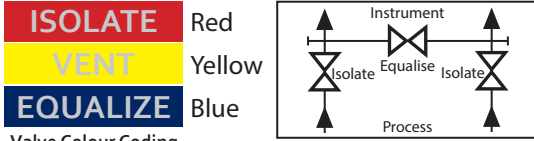

APPLICATION

Using The 3-Valve Manifold

In normal operation the "isolate" valves are open while the "equalize" valve is closed. This provides a differential pressure reading to the pressure gauge or transmitter.

To zero the instrument, first close the downstream "isolate" valve then open the "equalize" valve and adjust the zero setting on the instrument.

Also available in a range of other materials and options

(See HOW TO ORDER Data Sheet).

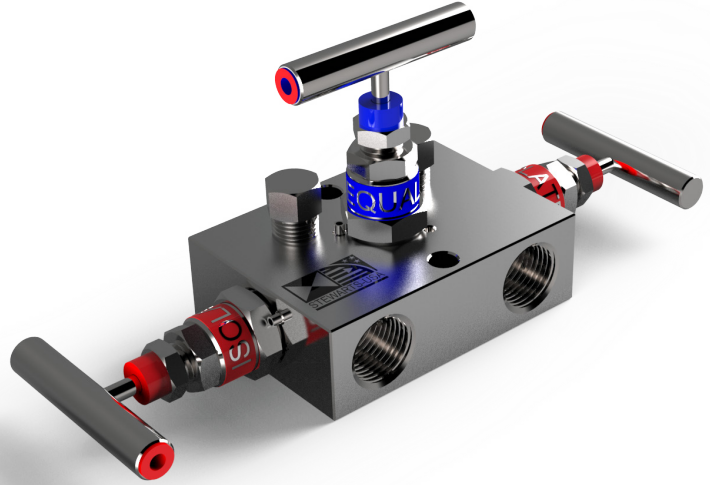

Weight = 3 lbs (1.4 kg)

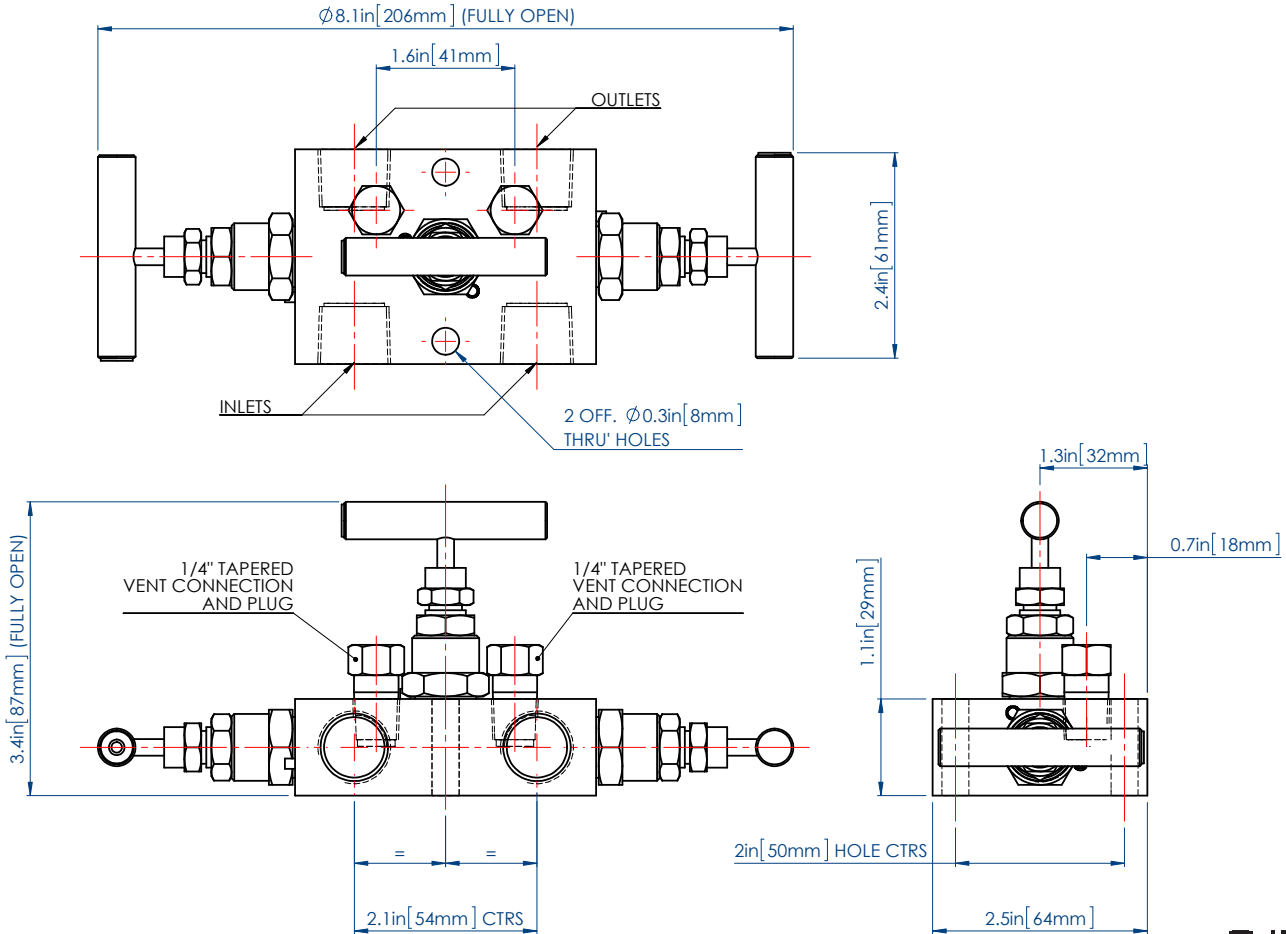

Dimensions shown in inches & mm

Stewarts - USA, LLC

6786 Tipperary, Houston, Texas 77061 USA
info@stewartusa.com

DATA SHEET REF: R3-REV01-15 SUS4

Phone: 713.643.1022. Fax: 713.643.2855. Toll Free: 800.901.1316

Web: www.STEWARTSUSA.com



MODEL - S3

DIRECT MOUNT (Angled Bonnet with Vent Plugs) THREE VALVE MANIFOLD 413 bar (6000 psi)



ISOLATE	Red
VENT	Yellow
EQUALIZE	Blue

Valve Colour Coding

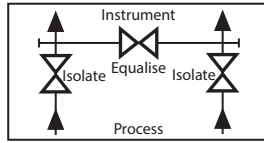

APPLICATION

Using The 3-Valve Manifold

In normal operation the "isolate" valves are open while the "equalize" valve is closed. This provides a differential pressure reading to the pressure gauge or transmitter. To zero the instrument, first close the downstream "isolate" valve then open the "equalize" valve and adjust the zero setting on the instrument. Also available in a range of other materials and options

(See HOW TO ORDER Data Sheet).

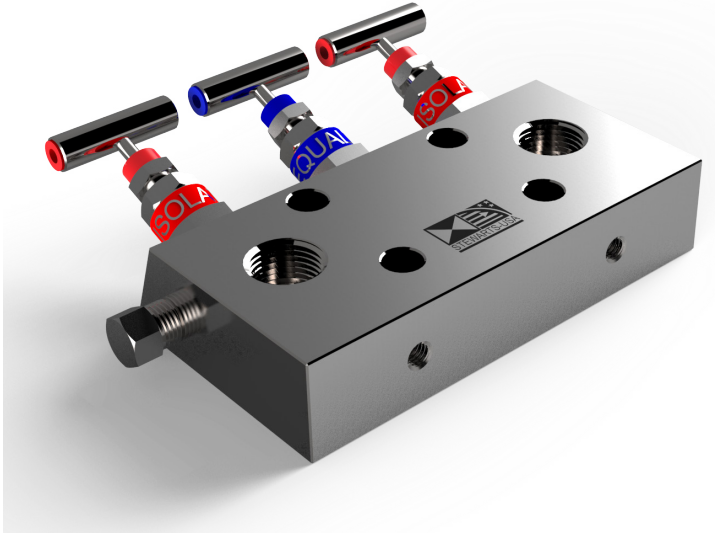

Weight = 6.4 lbs (2.9 kg)

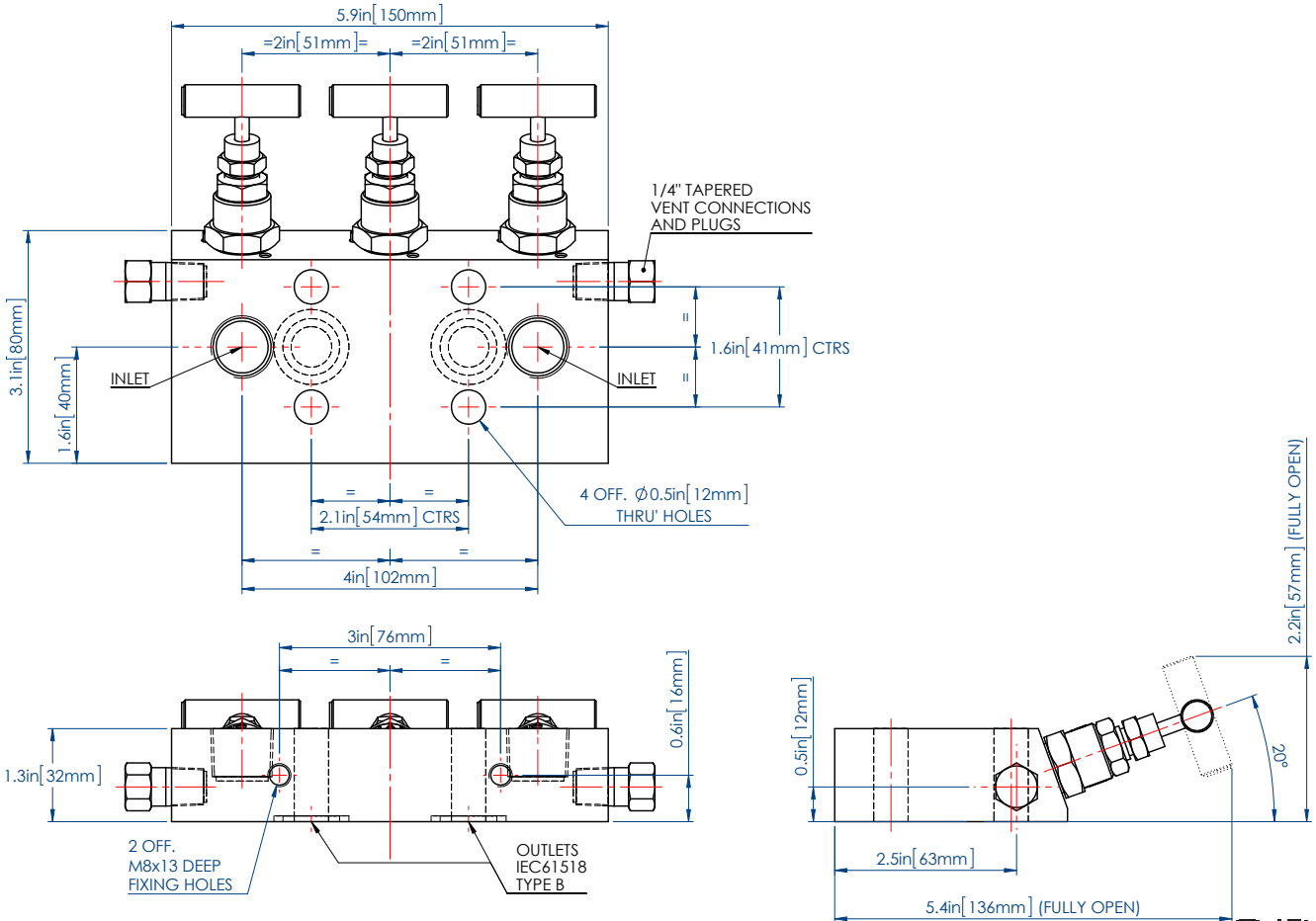

Dimensions shown in inches & mm

Stewarts - USA, LLC

6786 Tipperary, Houston, Texas 77061 USA
info@stewartusa.com

DATA SHEET REF: S3-REV01-15 SUS4

Phone: 713.643.1022. Fax: 713.643.2855. Toll Free: 800.901.1316

Web: www.STEWARTSUSA.com



MODEL - V3

REMOTE MOUNT (Pipe to Pipe) THREE VALVE MANIFOLD 413 bar (6000 psi)



ISOLATE	Red
VENT	Yellow
EQUALIZE	Blue

Valve Colour Coding

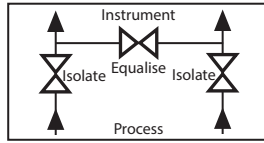

APPLICATION

Using The 3-Valve Manifold

In normal operation the "isolate" valves are open while the "equalize" valve is closed. This provides a differential pressure reading to the pressure gauge or transmitter. To zero the instrument, first close the downstream "isolate" valve then open the "equalize" valve and adjust the zero setting on the instrument. Also available in a range of other materials and options

(See HOW TO ORDER Data Sheet).

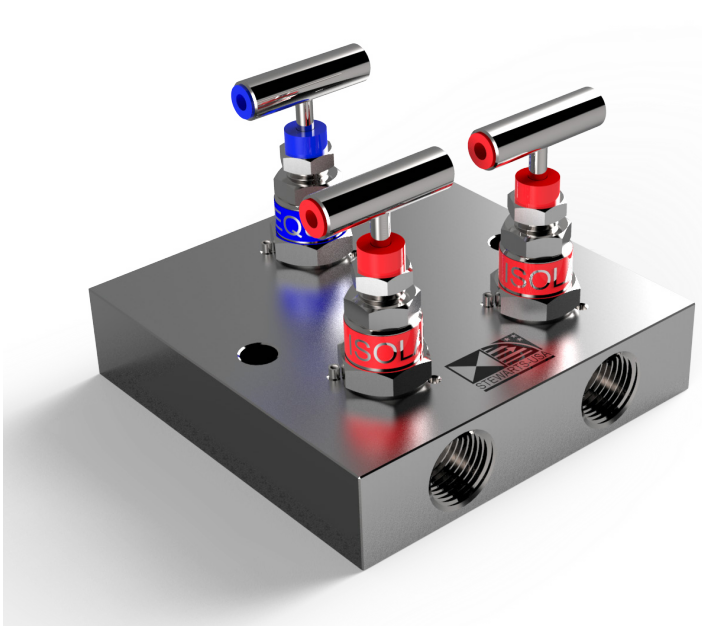

Weight = 7.2 lbs (3.3 kg)

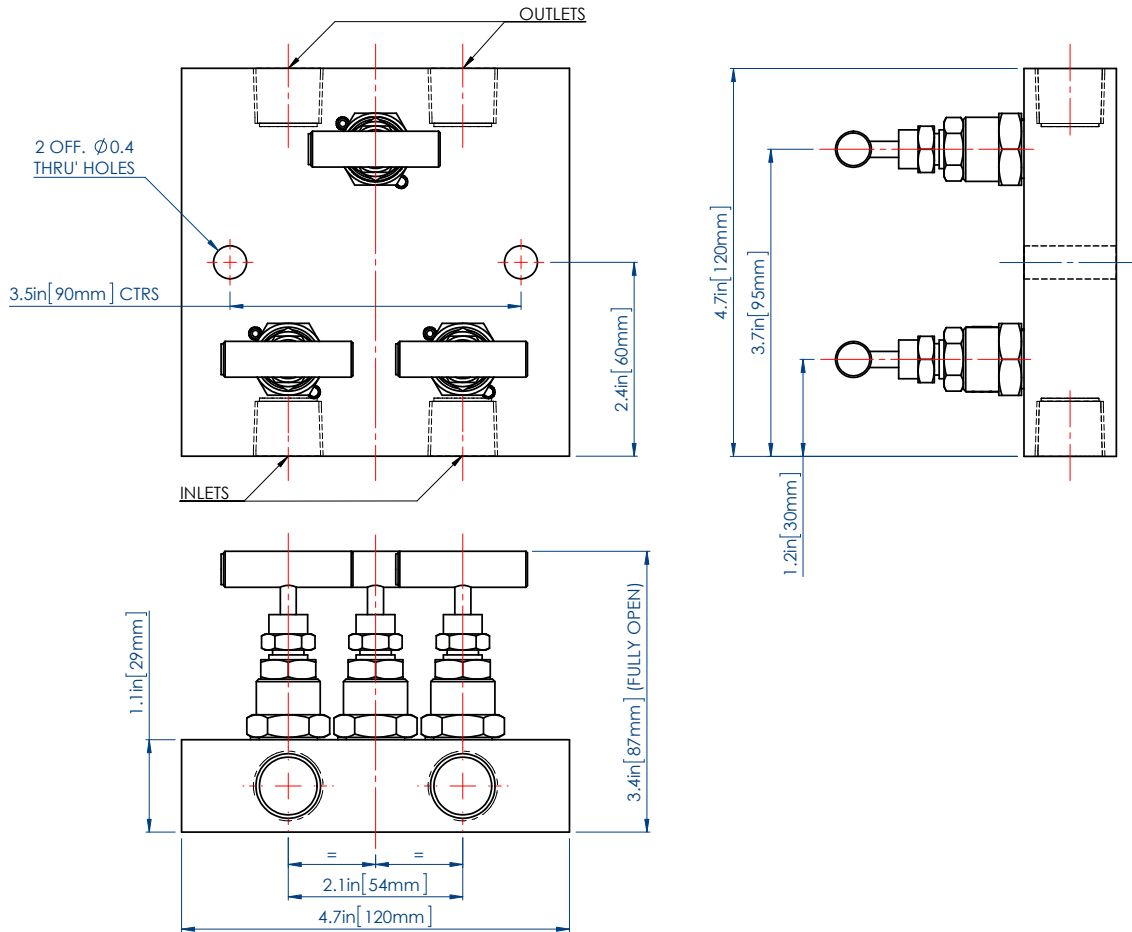

Dimensions shown in inches & mm

Stewarts - USA, LLC

6786 Tipperary, Houston, Texas 77061 USA
info@stewartusa.com

DATA SHEET REF: V3-REV01-15 SUS4

Phone: 713.643.1022. Fax: 713.643.2855. Toll Free: 800.901.1316

Web: www.STEWARTSUSA.com



5 - VALVE MANIFOLDS



STEWARTS 5-Valve Manifolds are Designed to reduce installation costs and improve safety performance, the consolidation of valves into one unit provides you with a combination of instrument isolation together with bleed/vent and test facilities.



Disclaimer:- Process pipework and structure in the above is for illustration purposes only; it does not reflect full requirement of a system installation and additional parts may be necessary.

Stewarts - USA, LLC

6786 Tipperary, Houston, Texas 77061 USA
info@stewartsusa.com

DATA SHEET REF: 5 DIVIDER-REV01-15 SUS4

Phone: 713.643.1022. Fax: 713.643.2855. Toll Free: 800.901.1316

Web: www.STEWARTSUSA.com



MODEL - R5

REMOTE MOUNT (Angled Bonnet Pipe to Pipe) FIVE VALVE MANIFOLD 413 bar (6000 psi)



ISOLATE	Red
VENT	Yellow
EQUALIZE	Blue

Valve Colour Coding

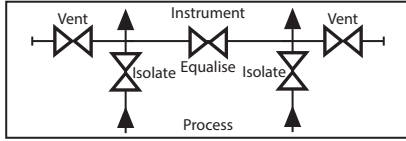

APPLICATION

Using the 5-valve manifold

In normal operation the "isolate" valves are open while the "equalise" and "vent" valves are closed. This provides a differential pressure reading to the pressure gauge or transmitter.

To zero the instrument, first close both "vent" valves and the downstream "isolate" valve. Then open the "equalise" valve and adjust the zero setting on the instrument. To remove the instrument, first close both "isolate" valves, then open the "equalise" valves to relieve pressure between the manifold and the instrument.

Calibration options

An option provided by 5-valve manifolds which is not available on 3-valve types is connecting the "vent" port to known pressure sources to check the calibration of the instrument.

Also available in a range of other materials and options (See HOW TO ORDER Data Sheet).

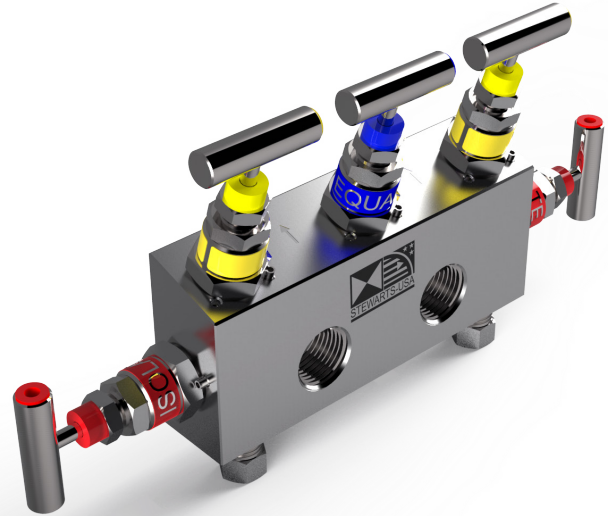

Weight = 5.3 lbs (2.4 kg)

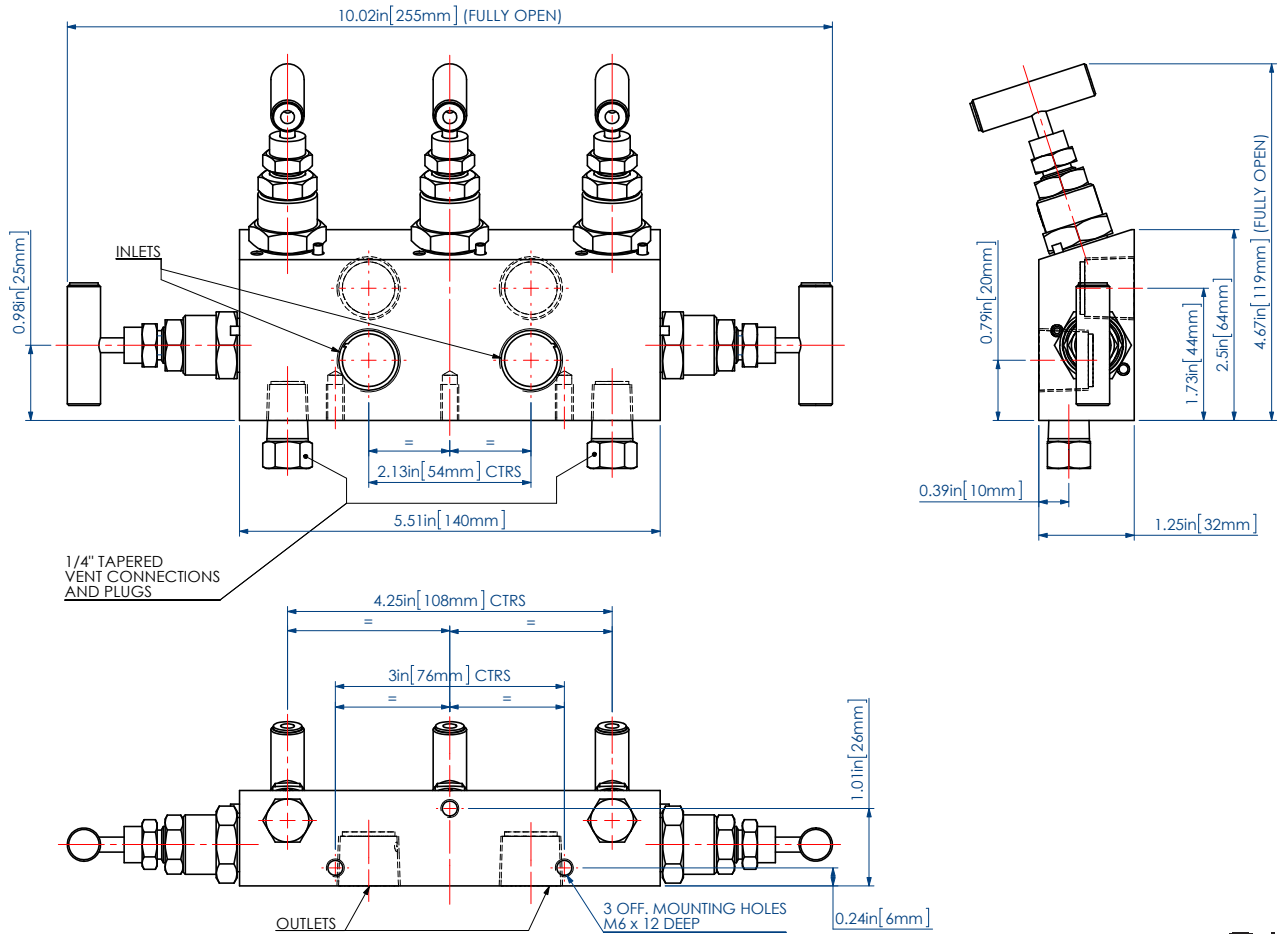

Dimensions shown in inches & mm

Stewarts - USA, LLC

6786 Tipperary, Houston, Texas 77061 USA
info@stewartusa.com

DATA SHEET REF: R5-REV01-15 SUSA

Phone: 713.643.1022. Fax: 713.643.2855. Toll Free: 800.901.1316

Web: www.STEWARTSUSA.com



MODEL - T5

REMOTE MOUNT (Pipe to Pipe)

FIVE VALVE MANIFOLD 413 bar (6000 psi)



ISOLATE	Red
VENT	Yellow
EQUALIZE	Blue

Valve Colour Coding

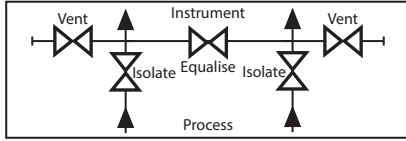

APPLICATION

Using the 5-valve manifold

In normal operation the "isolate" valves are open while the "equalise" and "vent" valves are closed. This provides a differential pressure reading to the pressure gauge or transmitter.

To zero the instrument, first close both "vent" valves and the downstream "isolate" valve. Then open the "equalise" valve and adjust the zero setting on the instrument. To remove the instrument, first close both "isolate" valves, then open the "equalise" valves to relieve pressure between the manifold and the instrument.

Calibration options

An option provided by 5-valve manifolds which is not available on 3-valve types is connecting the "vent" port to known pressure sources to check the calibration of the instrument.

Also available in a range of other materials and options

(See HOW TO ORDER Data Sheet).

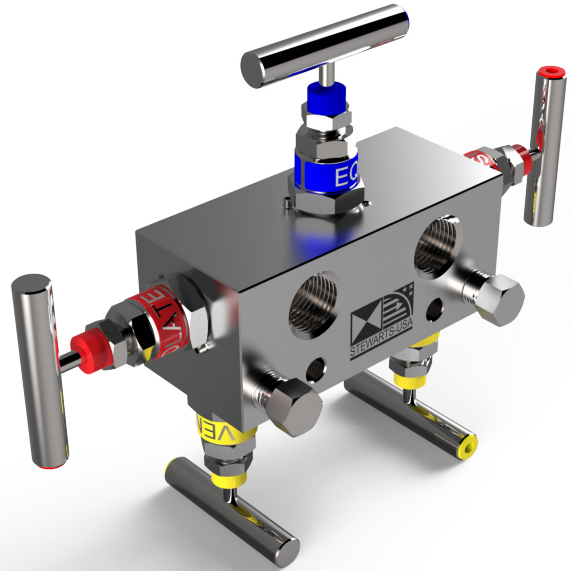

Weight = 6 lbs (2.7 kg)

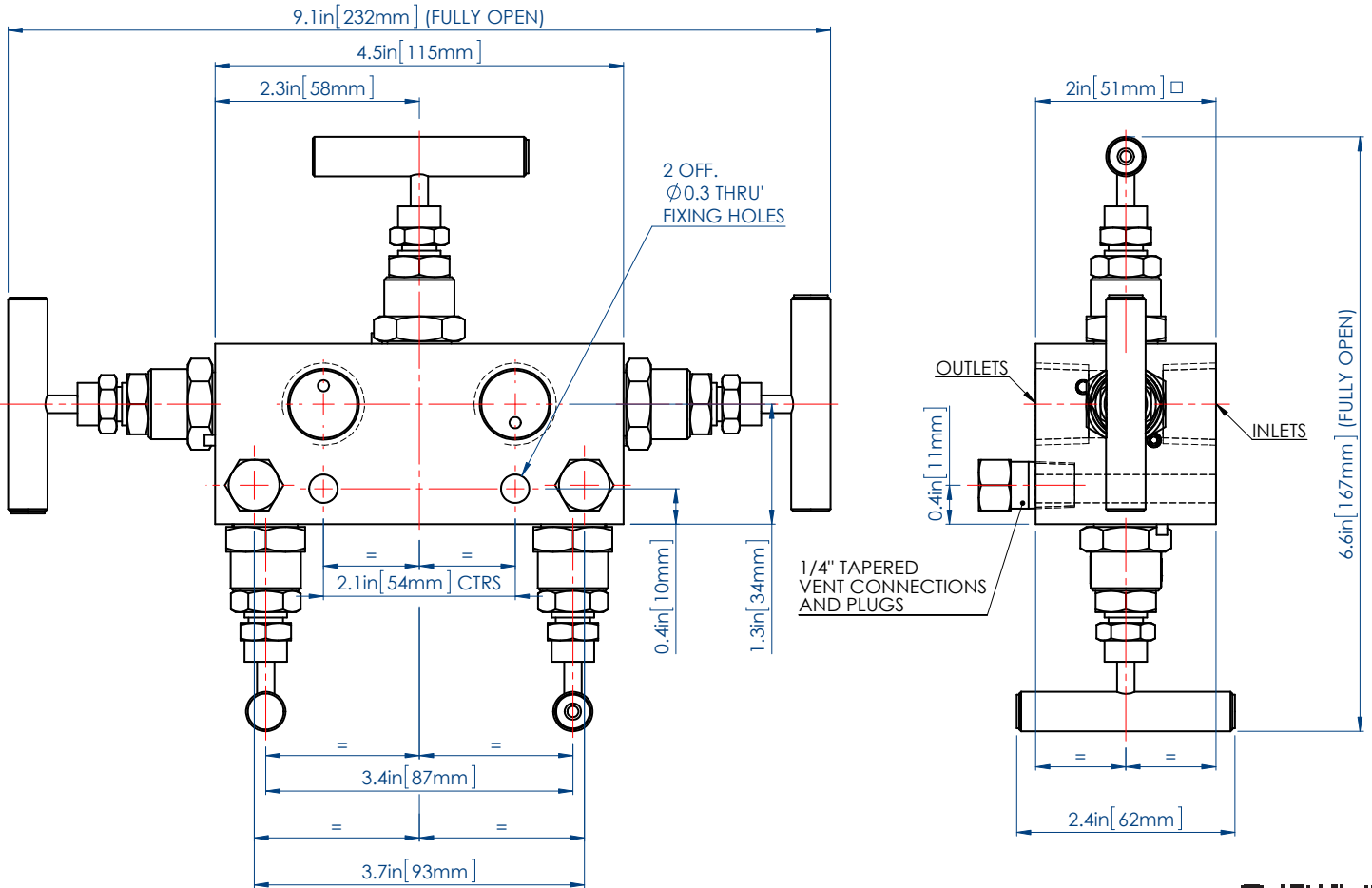

Dimensions shown in inches & mm

Stewarts - USA, LLC

6786 Tipperary, Houston, Texas 77061 USA
info@stewartsusa.com

DATA SHEET REF: T5-REV01-15 SUSA

Phone: 713.643.1022. Fax: 713.643.2855. Toll Free: 800.901.1316

Web: www.STEWARTSUSA.com



MODEL - U5

DIRECT MOUNT (Angled Bonnet Pipe to Pipe) FIVE VALVE MANIFOLD 413 bar (6000 psi)



ISOLATE	Red
VENT	Yellow
EQUALIZE	Blue

Valve Colour Coding

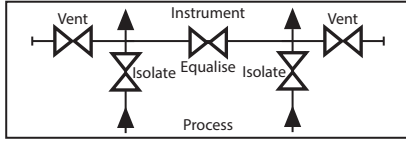

APPLICATION

Using the 5-valve manifold

In normal operation the "isolate" valves are open while the "equalise" and "vent" valves are closed. This provides a differential pressure reading to the pressure gauge or transmitter.

To zero the instrument, first close both "vent" valves and the downstream "isolate" valve. Then open the "equalise" valve and adjust the zero setting on the instrument. To remove the instrument, first close both "isolate" valves, then open the "equalise" valves to relieve pressure between the manifold and the instrument.

Calibration options

An option provided by 5-valve manifolds which is not available on 3-valve types is connecting the "vent" port to known pressure sources to check the calibration of the instrument.

Also available in a range of other materials and options
(See HOW TO ORDER Data Sheet).

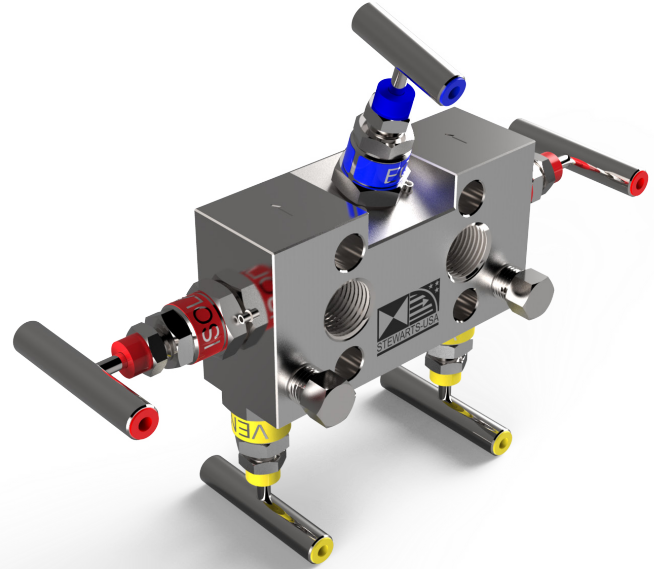

Weight = 5.5 lbs (2.5 kg)

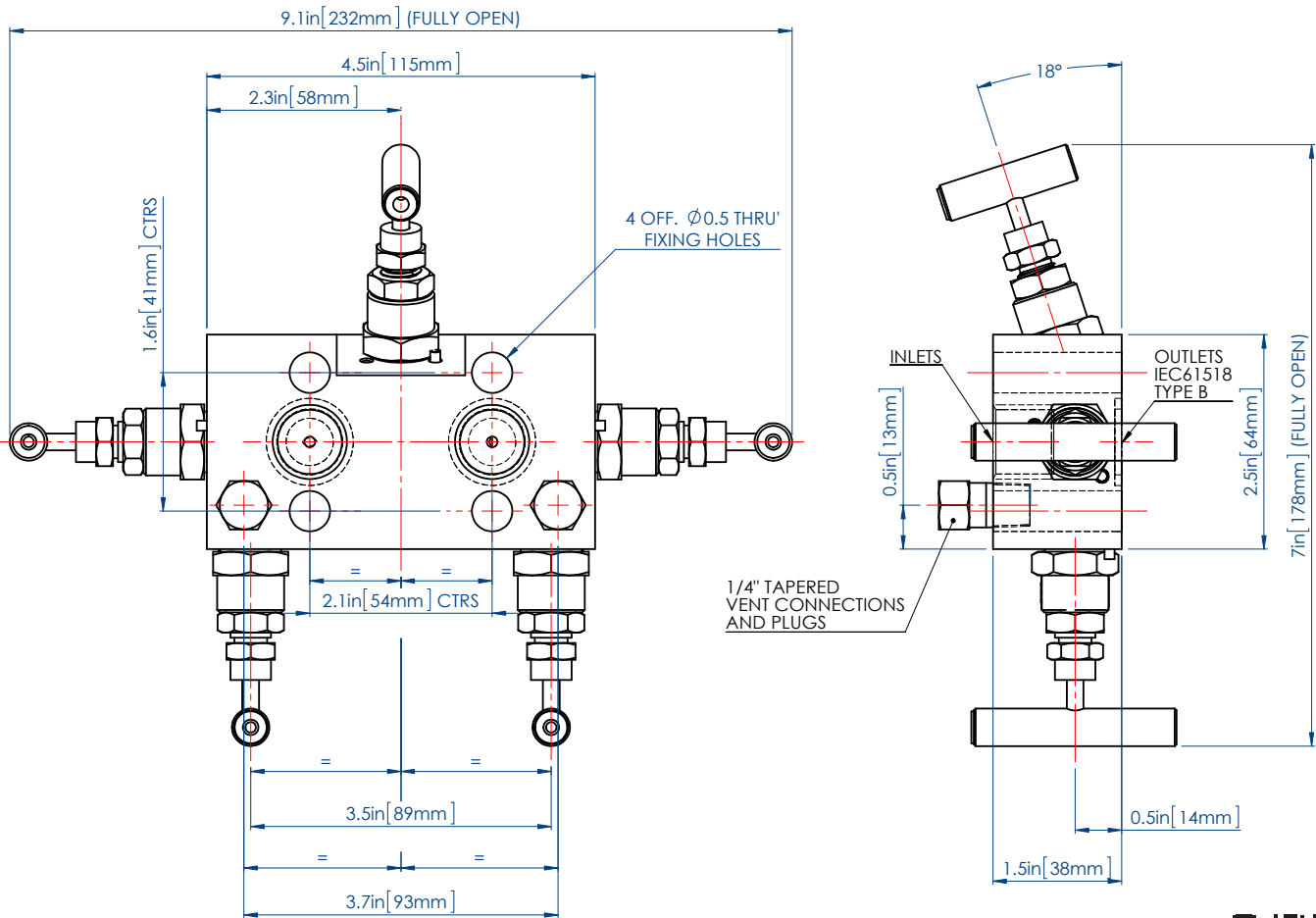

Dimensions shown in inches & mm

Stewarts - USA, LLC

6786 Tipperary, Houston, Texas 77061 USA
info@stewartsusa.com

DATA SHEET REF: US-REV01-15 SUS4

Phone: 713.643.1022. Fax: 713.643.2855. Toll Free: 800.901.1316

Web: www.STEWARTSUSA.com



MODEL - V5

REMOTE MOUNT (Flat Face Pipe to Pipe) FIVE VALVE MANIFOLD 413 bar (6000 psi)



ISOLATE	Red
VENT	Yellow
EQUALIZE	Blue

Valve Colour Coding

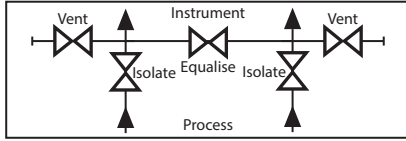

APPLICATION

Using the 5-valve manifold

In normal operation the "isolate" valves are open while the "equalise" and "vent" valves are closed. This provides a differential pressure reading to the pressure gauge or transmitter.

To zero the instrument, first close both "vent" valves and the downstream "isolate" valve. Then open the "equalise" valve and adjust the zero setting on the instrument. To remove the instrument, first close both "isolate" valves, then open the "equalise" valves to relieve pressure between the manifold and the instrument.

Calibration options

An option provided by 5-valve manifolds which is not available on 3-valve types is connecting the "vent" port to known pressure sources to check the calibration of the instrument.

Also available in a range of other materials and options (See HOW TO ORDER Data Sheet).

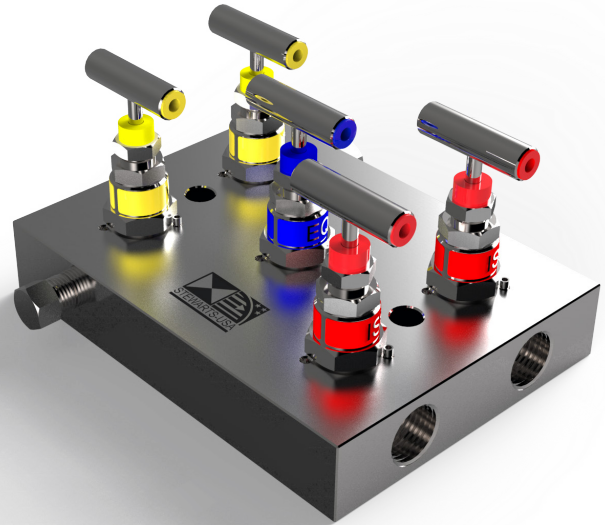

Weight = 10.4 lbs (4.7 kg)

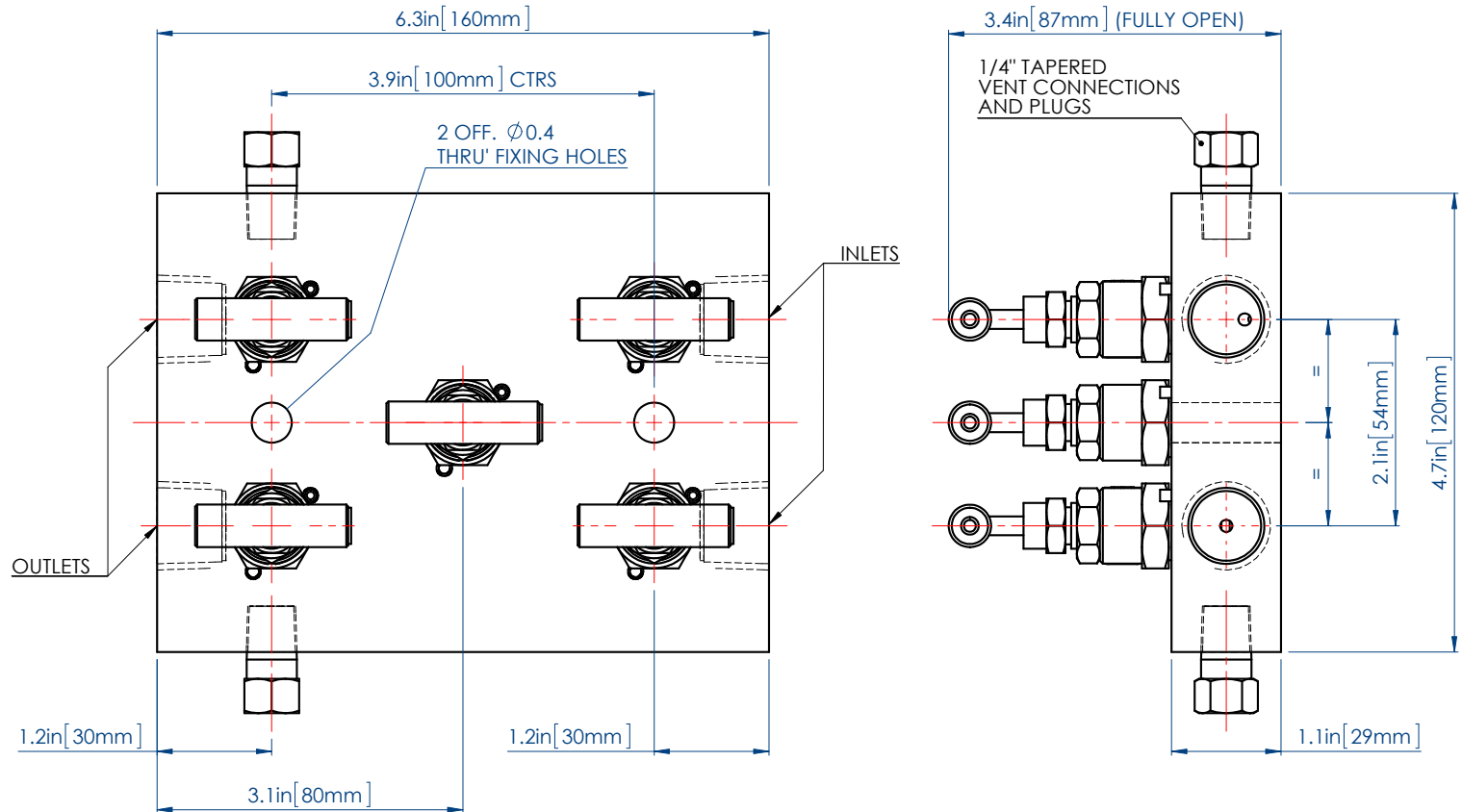

Dimensions shown in inches & mm

Stewarts - USA, LLC

6786 Tipperary, Houston, Texas 77061 USA
info@stewartusa.com

DATA SHEET REF: V5-REV01-15 SUS4

Phone: 713.643.1022. Fax: 713.643.2855. Toll Free: 800.901.1316

Web: www.STEWARTSUSA.com



MODEL - W5

ENCLOSURE MOUNT (Pipe to Flange)

FIVE VALVE MANIFOLD 413 bar (6000 psi)



ISOLATE	Red
VENT	Yellow
EQUALIZE	Blue

Valve Colour Coding

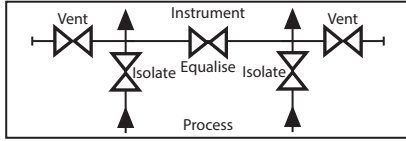

APPLICATION

Using the 5-valve manifold

In normal operation the "isolate" valves are open while the "equalise" and "vent" valves are closed. This provides a differential pressure reading to the pressure gauge or transmitter.

To zero the instrument, first close both "vent" valves and the downstream "isolate" valve. Then open the "equalise" valve and adjust the zero setting on the instrument. To remove the instrument, first close both "isolate" valves, then open the "equalise" valves to relieve pressure between the manifold and the instrument.

Calibration options

An option provided by 5-valve manifolds which is not available on 3-valve types is connecting the "vent" port to known pressure sources to check the calibration of the instrument.

Also available in a range of other materials and options

(See HOW TO ORDER Data Sheet).

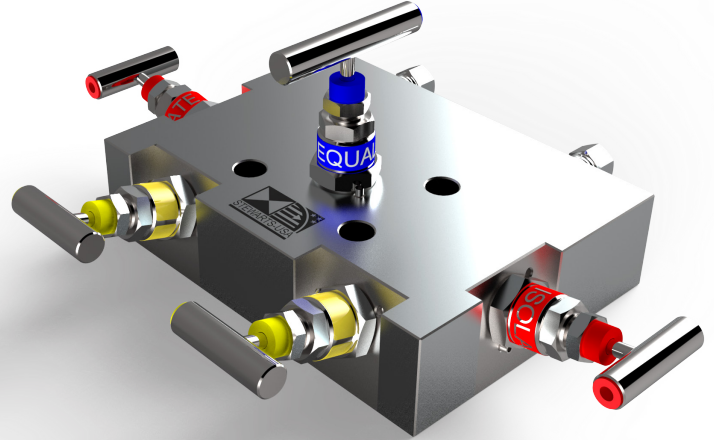

Weight = 12.8 lbs (5.8 kg)

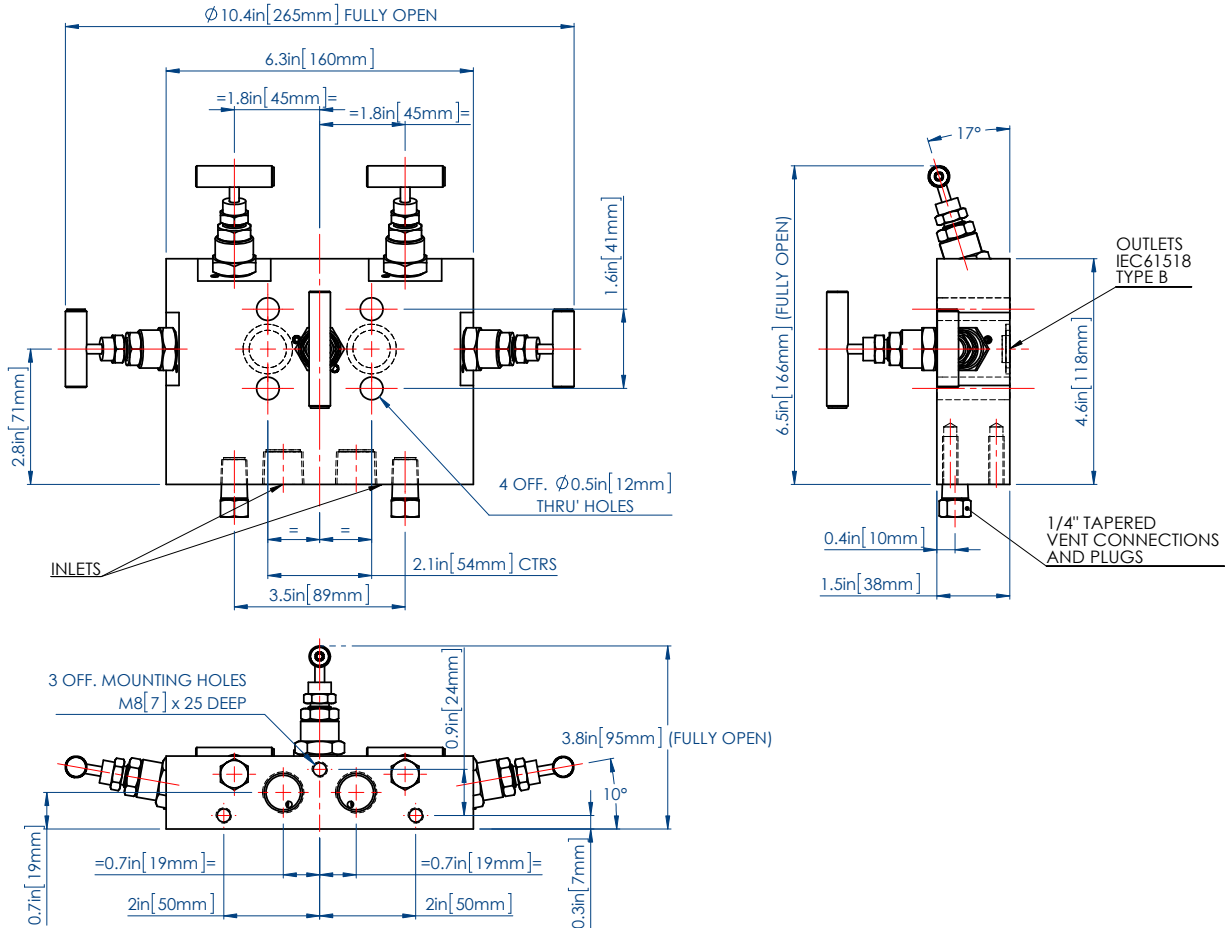

Dimensions shown in inches & mm

Stewarts - USA, LLC

6786 Tipperary, Houston, Texas 77061 USA
info@stewartusa.com

DATA SHEET REF: V5-REV01-15 SUSA

Phone: 713.643.1022. Fax: 713.643.2855. Toll Free: 800.901.1316

Web: www.STEWARTSUSA.com



MODEL - X5

DIRECT MOUNT (Angled Bonnet Flange to Flange) FIVE VALVE MANIFOLD 413 bar (6000 psi)



ISOLATE	Red
VENT	Yellow
EQUALIZE	Blue

Valve Colour Coding

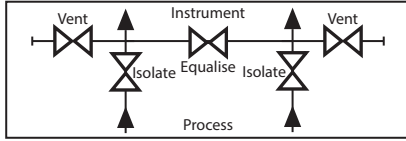

APPLICATION

Using the 5-valve manifold

In normal operation the "isolate" valves are open while the "equalise" and "vent" valves are closed. This provides a differential pressure reading to the pressure gauge or transmitter.

To zero the instrument, first close both "vent" valves and the downstream "isolate" valve. Then open the "equalise" valve and adjust the zero setting on the instrument. To remove the instrument, first close both "isolate" valves, then open the "equalise" valves to relieve pressure between the manifold and the instrument.

Calibration options

An option provided by 5-valve manifolds which is not available on 3-valve types is connecting the "vent" port to known pressure sources to check the calibration of the instrument.

Also available in a range of other materials and options (See HOW TO ORDER Data Sheet).

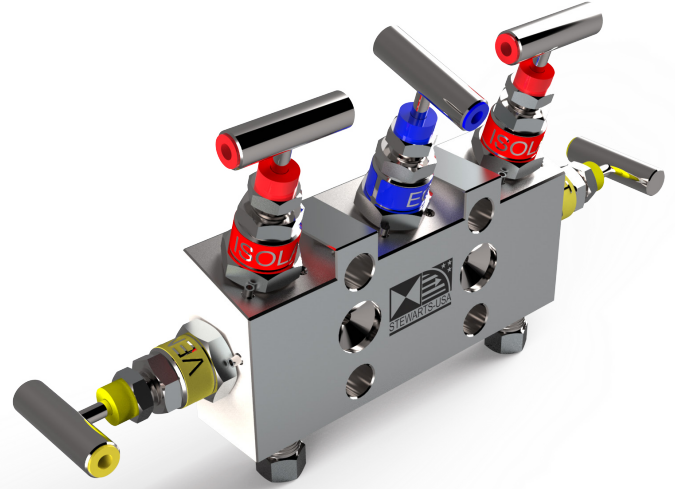

Weight = 5.3 lbs (2.4 kg)

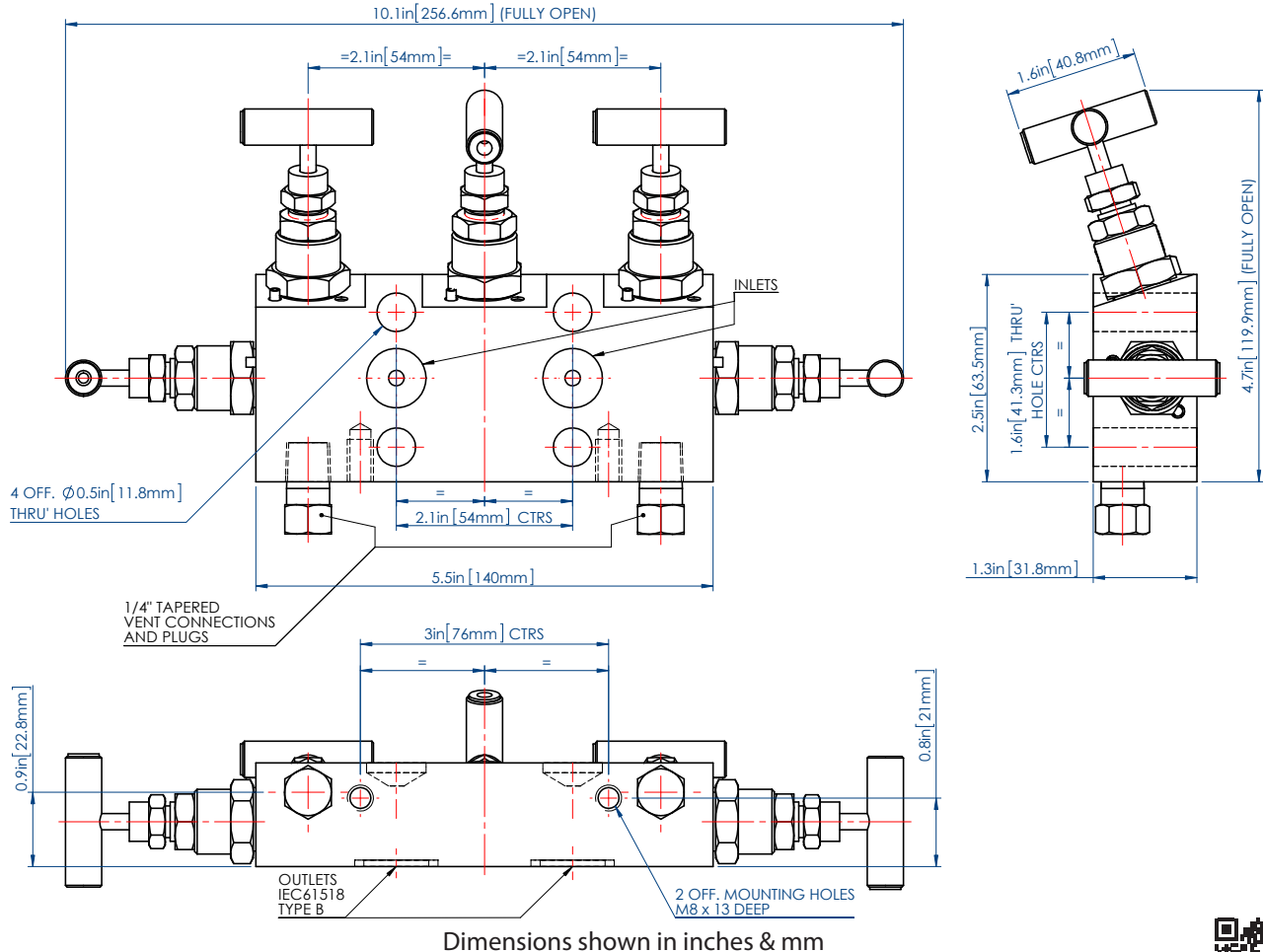

Stewarts - USA, LLC

6786 Tipperary, Houston, Texas 77061 USA
info@stewartusa.com

DATA SHEET REF: X5-REV01-15 SUSA

Phone: 713.643.1022. Fax: 713.643.2855. Toll Free: 800.901.1316

Web: www.STEWARTSUSA.com



ENCLOSURE MOUNTED VALVE MANFOLDS



The STEWARTS E2, E3 & E5 Series manifolds are manufactured for applications that require the transmitter to be mounted in an enclosure for environmental protection. Although our standard transmitter manifolds will work, the 'E' series is designed to save space and to simplify the mounting of the transmitter in the enclosure. Additionally, the 'E' series presents the valve handles for easy operation of the valves. Process connections, and mounting holes are situated on the bottom of the manifold to simplify piping.

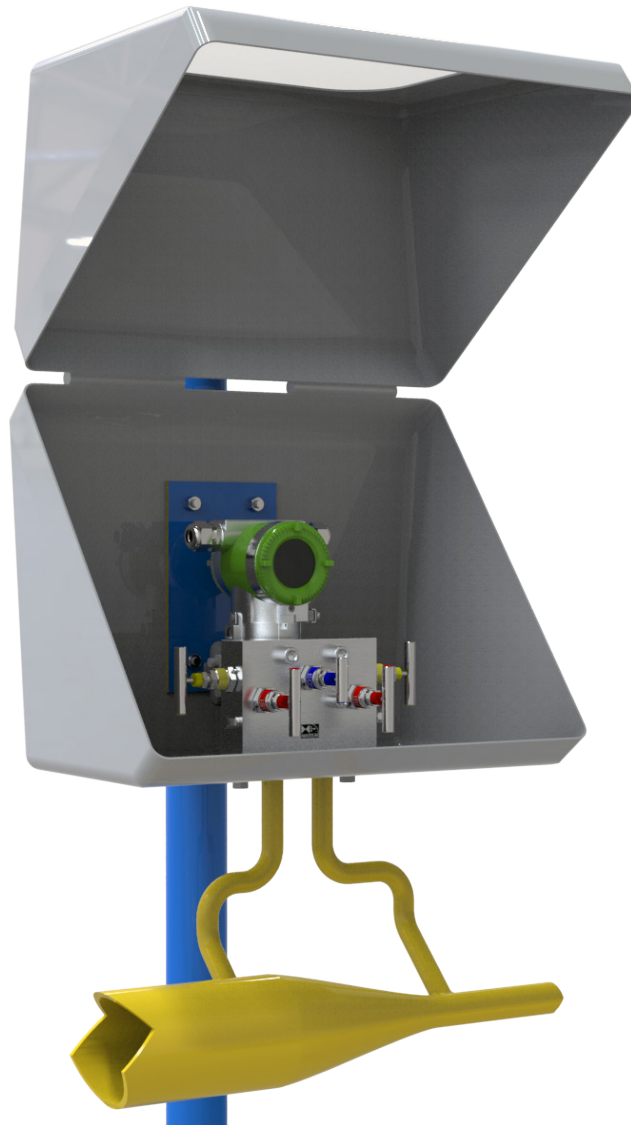

Disclaimer:- Process pipework and structure in the above is for illustration purposes only; it does not reflect full requirement of a system installation and additional parts may be necessary.

Dimensions shown in inches & mm

Stewarts - USA, LLC

6786 Tipperary, Houston, Texas 77061 USA
info@stewartsusa.com

DATA SHEET REF: ENCLOSURE-REV01-15 SUSAS

Phone: 713.643.1022. Fax: 713.643.2855. Toll Free: 800.901.1316

Web: www.STEWARTSUSA.com



MODEL - EM2

ENCLOSURE MOUNT BLOCK AND BLEED (Angled Bonnet) TWO VALVE MANIFOLD 413 bar (6000 psi)



ISOLATE	Red
VENT	Yellow
EQUALIZE	Blue

Valve Colour Coding

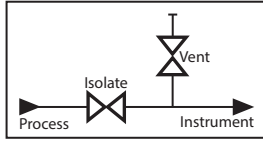

APPLICATION

Using The 2-Valve Manifold

In normal operation the "isolate" valve is open while the "vent" valve is closed. To remove the instrument, first close the "isolate" valve, then open the "vent" valve to relieve pressure upstream of the "isolate" valve.

Calibration Options

By connecting a calibration gauge to the vent port, it is possible to check the calibration of the instrument without removing it from the installation.

Also available in a range of other materials and options
(See HOW TO ORDER Data Sheet)



Weight = 2.9 lbs (1.3 kg)

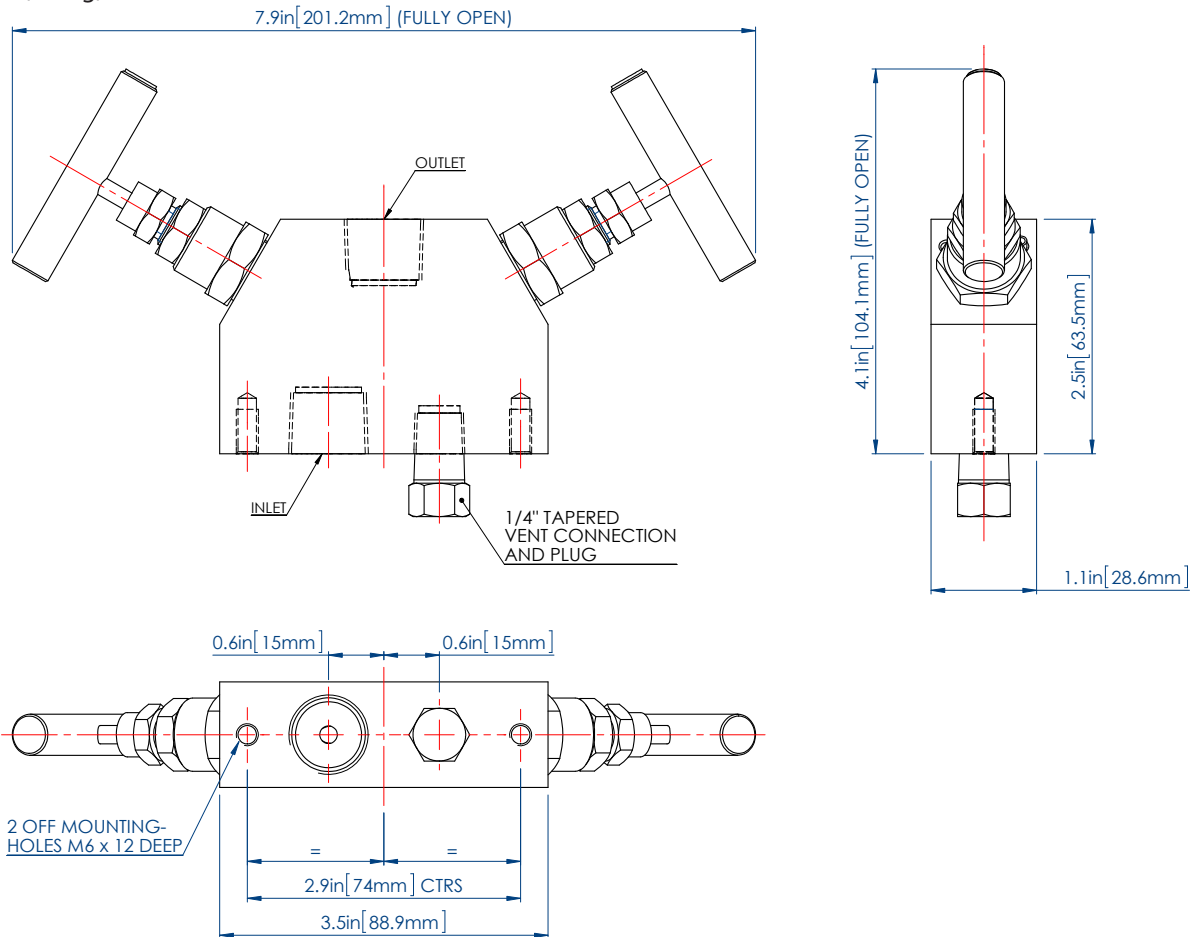

Dimensions shown in inches & mm

Stewarts - USA, LLC

6786 Tipperary, Houston, Texas 77061 USA
info@stewartsusa.com

DATA SHEET REF: EM2-REV01-15 SUS4

Phone: 713.643.1022. Fax: 713.643.2855. Toll Free: 800.901.1316

Web: www.STEWARTSUSA.com



MODEL - EM3

ENCLOSURE MOUNT (With Vent Plugs) THREE VALVE MANIFOLD 413 bar (6000 psi)



ISOLATE	Red
VENT	Yellow
EQUALIZE	Blue

Valve Colour Coding

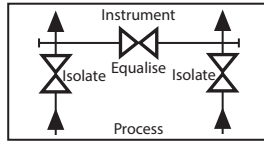

APPLICATION

Using The 3-Valve Manifold

In normal operation the "isolate" valves are open while the "equalize" valve is closed.

This provides a differential pressure reading to the pressure gauge or transmitter. To zero the instrument, first close the downstream "isolate" valve then open the "equalize" valve and adjust the zero setting on the instrument.

Available with integral steam channel for low temperature applications.

Also available in a range of other materials and options (See HOW TO ORDER Data Sheet).

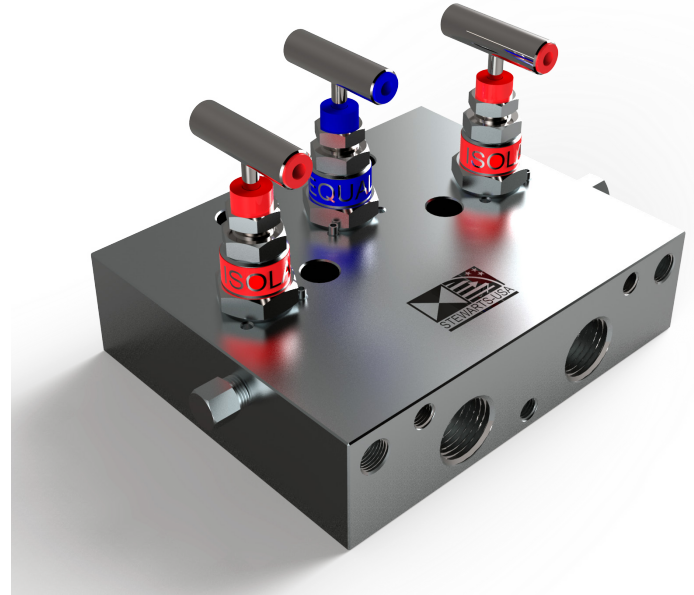

Weight = 11.5 lbs (5.2 kg)

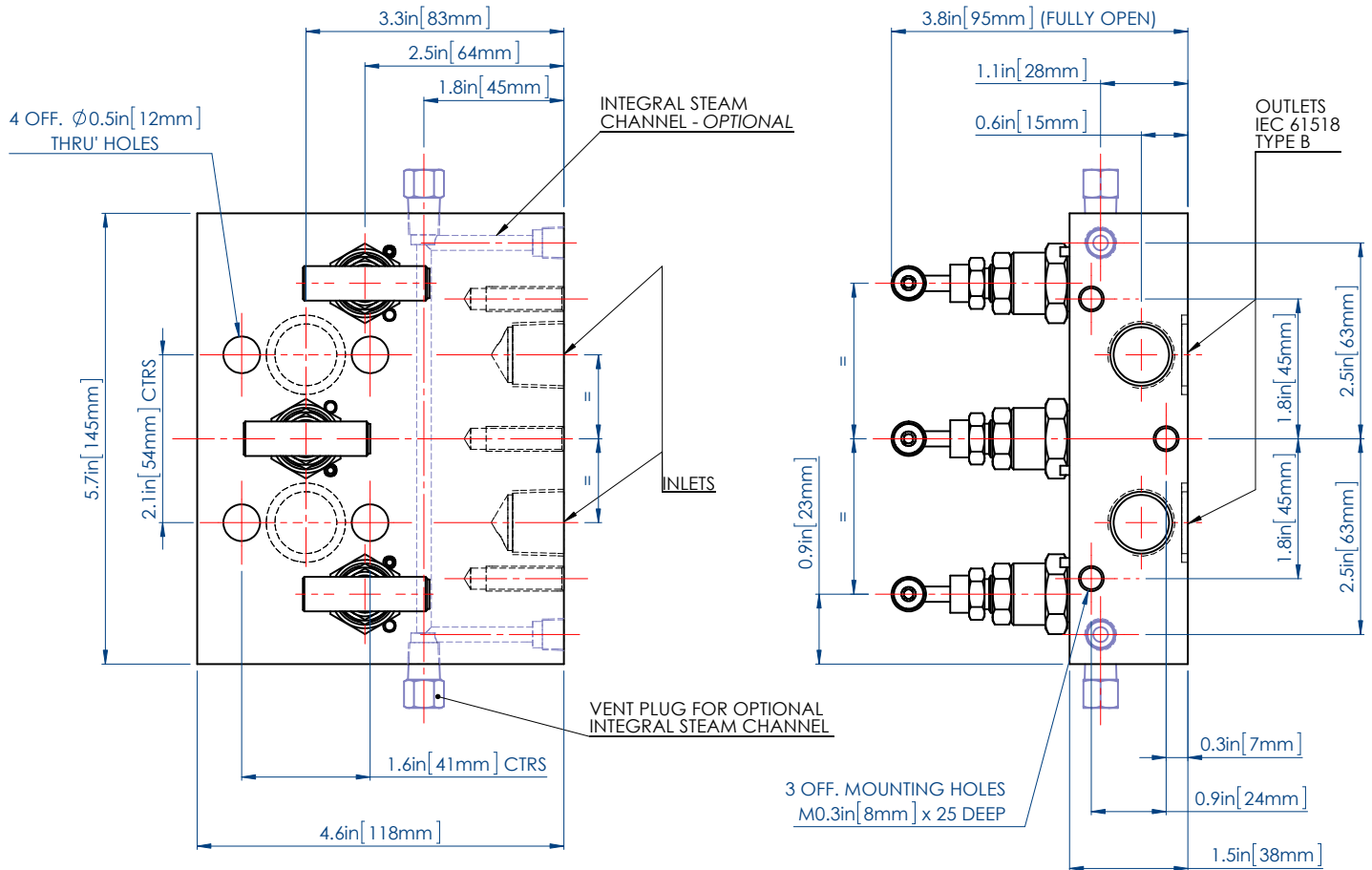

Dimensions shown in inches & mm

Stewarts - USA, LLC

6786 Tipperary, Houston, Texas 77061 USA
info@stewartusa.com

DATA SHEET REF: EM3-REV01-15 SUS4

Phone: 713.643.1022. Fax: 713.643.2855. Toll Free: 800.901.1316

Web: www.STEWARTSUSA.com



POSITIVE MATERIAL IDENTIFICATION (PMI)



Using our X-ray fluorescence (XRF) analyser we can carry out non-destructive Positive material identification (PMI) to provide highly specific material chemistry to rapidly and accurately identify alloy grades and pure metals.

PMI Testing enables a component's material grade or chemical analysis to be found. PMI testing is one of the more specialized non-destructive testing methods. With PMI Testing the alloy composition of materials can be determined. If a material certificate is missing or it is not clear what the composition of a material is, then PMI Testing offers the solution.

PMI Testing is particularly used for high-quality metals like stainless steel and high alloy metals. While engineers push the boundaries of material capacities to their limits in the design, assurance that the proper material is used becomes ever more important.

Specifications and dimensions in this leaflet, are subject to change without prior notice.

Stewarts - USA, LLC

6786 Tipperary, Houston, Texas 77061 USA
info@stewartsusa.com

DATA SHEET REF: PMI-REV01-15 SUS4

Phone: 713.643.1022. Fax: 713.643.2855. Toll Free: 800.901.1316

Web: www.STEWARTSUSA.com



VIDEO BORESCOPE INSPECTION

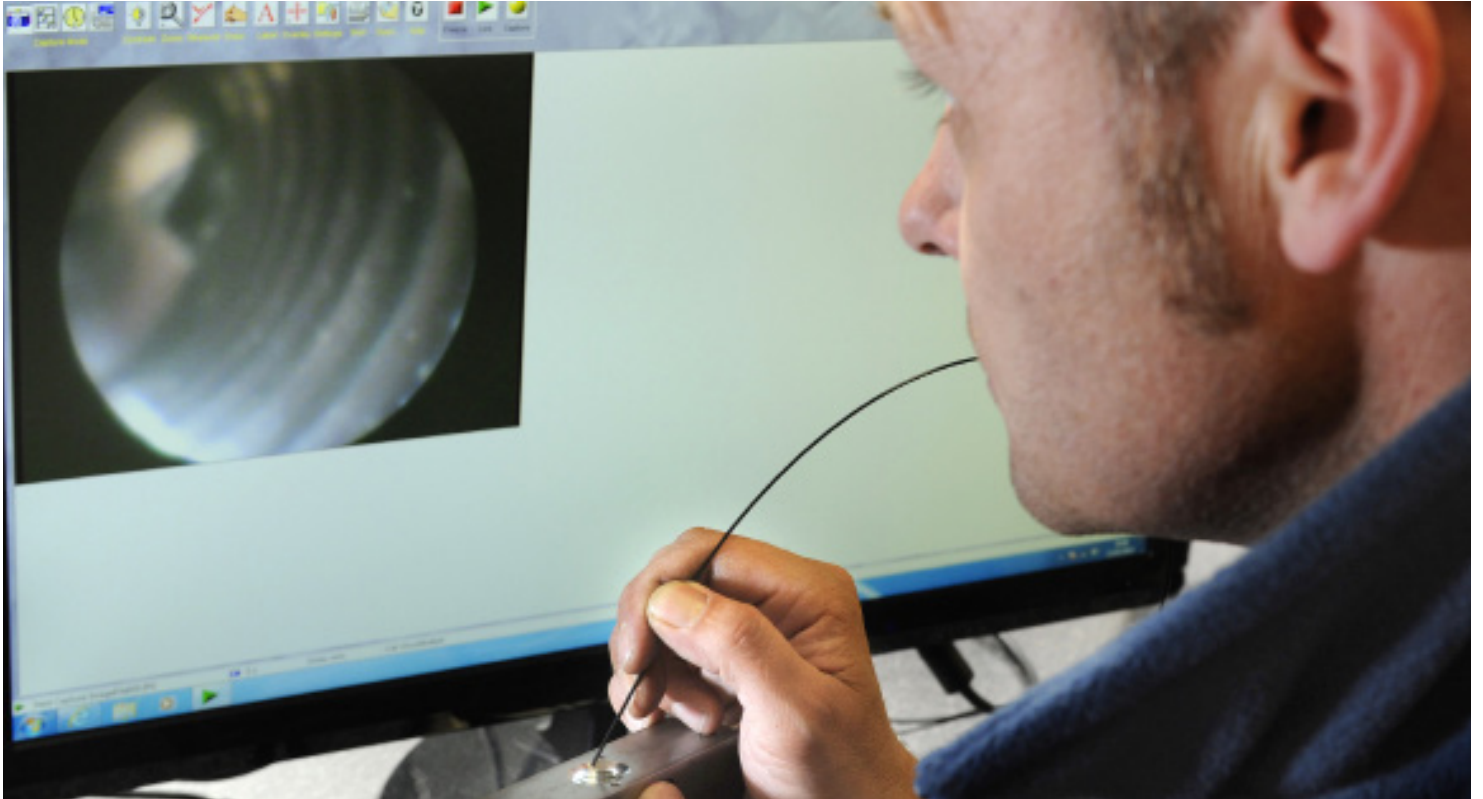

STEWARTS use a Flexible Video Borescope for non-destructive visual inspection. This allows for an internal visual inspection for burrs, defects, surface finish irregularities in our valves and manifolds.



Burr in a cross hole

Specifications and dimensions in this leaflet, are subject to change without prior notice.

Stewarts - USA, LLC

6786 Tipperary, Houston, Texas 77061 USA
info@stewartsusa.com

DATA SHEET REF: BORESCOPE-REV01-15 SUS4

Phone: 713.643.1022. Fax: 713.643.2855. Toll Free: 800.901.1316

Web: www.STEWARTSUSA.com



Needle Valves & Manifolds

1 MATERIALS

- Materials must be compatible with medium.
- Pressure and temperature also have direct bearing on the correct seal & body material to be used and must be considered when specifying. See pressure/temperature ratings table contained in our printed literature. If in any doubt, consult STEWARTS.

2 THREADS AND JOINTING

- All pressure connections should be leak tight and should be observed when first applying pressure.
- Recommended maximum operating pressure for each size of thread and type of material must not be exceeded. Please note the stated pressures represent the maximum applied pressure. If in doubt, consult the manufacturer.
- Care must be taken to ensure mis-match of threads does not occur.
- Mating female connections must have a pressure rating that is compatible with the pressure range of the product.
- Valves with parallel threads must have the independent seal made on the flat seating using a washer or bonded seal of material compatible with the pressure medium.
- Valves with tapered threads have the joint made by mating of the threads. It is common practice to apply jointing material to the male thread. This must be compatible with the pressure medium and applied in the correct quantity to ensure non-interference with the mating of the thread
- NPT and other tapered thread forms when manufactured to the standard specification may not be adequate to offer sufficient thread engagement for safe use under pressure.
- Particular care must be taken to ensure the valve has the correct pressure rating for the application.

3 INSTALLATION

- When joining up a valve to the system, the system must not be pressurized.
- If the valve is already fitted to a gauge at time of installation, the valve should be in the closed position to prevent the build-up of pressure from entering the gauge. The valve should then be opened slowly and care taken to ensure the pressure entering the gauge does not exceed its pressure rating.
- When the valve does not have a gauge fitted at time of installation (i.e., with an open port) the valve should be in the open position which will prevent build-up of pressure within the valve. Care should therefore be taken to confirm that all systems are sealed before pressurizing.
- Manifolds and equalizing valves are accompanied by specific installation instructions and these should be referred to before proceeding with installation.

MAINTENANCE

4a

- Valves etc. should be part of a planned maintenance programme to ensure they continue to function properly.
- The time interval between examinations will vary depending upon site conditions, the number of opening and shutting operations etc. and should be determined in the light of experience.
- Threaded connections should be checked for leaks and tightened as required.
- If leaking through the packing is evident, loosen locknut, tighten packing compression bolt to torque rating of 13 lbs/ft (18 Nm) minimum to 18 lbs/ft (25 Nm) maximum and re-tighten locknut.

MAINTENANCE - HIGH PRESSURE VALVES

4b

- Valves etc. should be part of a planned maintenance programme to ensure they continue to function properly.
- The time interval between examinations will vary depending upon site conditions, the number of opening and shutting operations etc. and should be determined in the light of experience.
- Threaded connections should be checked for leaks and tightened as required.
- If leaking through the packing is evident, loosen locking device, tighten glandnut to torque rating of 49 lbs/ft (68 Nm) and re-tighten locking device.

Continued on Next Page



REPAIRS

5a

- The design of these valves allows packing or whole stem assembly to be replaced without removing the valve from the system. The system must be closed down and any residual pressure exhausted in a controlled manner before proceeding.
- To replace packing: - Remove handle, slacken locknut, remove compression bolt and compression gland ring. Remove packing and replace. Re-assemble in reverse order to the above and tighten to torque described in Paragraph 4a.
- To replace whole stem assembly: - Remove handle and bonnet locking pin. Remove whole head assembly (N.B. To loosen - turn anti-clockwise). Slacken locknut, remove compression bolt and compression gland ring. Remove stem assembly by withdrawing downwards. Fit new stem assembly and packing.
Re-assemble in reverse order to the above and tighten compression bolt to torque described in Paragraph 4a.
Re-fit head assembly to valve body and tighten to torque of 100 lbs/ft (135.58Nm) Replace locking pin. Test valve for leaks.
Note: Ensure stem is screwed fully into the bonnet before refitting to body. Fit locking pin, after testing.
- If the valve seat is damaged, the whole valve should be replaced.

REPAIRS HIGH PRESSURE VALVES

5b

- The design of these valves allows packing or whole stem assembly to be replaced without removing the valve from the system. The system must be closed down and any residual pressure exhausted in a controlled manner before proceeding.
- To replace packing: - Remove handle if necessary, loosen and and remove locking device from gland nut hex, remove gland nut and compression gland ring
Re-assemble in reverse order to the above and ensure that rotating stem is fully screwed into gland nut. tighten to torque described in Paragraph 4b.
- To replace whole stem assembly: - Remove handle and bonnet locking device. Remove whole head assembly (N.B. To loosen - turn anti-clockwise). If necessary, remove packing and compression gland ring from non rotating stem. Remove stem assembly by rotating upper stem and withdrawing downwards.
Fit new stem assembly and packing.
Re-assemble in reverse order to the above and tighten compression bolt to torque described in Paragraph 4b.
Re-fit head assembly to valve body and tighten to torque of 49lbs/ft (68Nm) Replace locking device. Test valve for leaks.
Note: Ensure stem is screwed fully into the bonnet before refitting to body. Fit locking device, after testing.
- If the valve seat is damaged, the whole valve should be replaced.

6 SPARES

- We recommend that spares should be held in the form of whole stem assemblies. (and PCTFE packing for High Pressure Valves)
Note: It is the responsibility of the customer to select the proper valve.
If in any doubt, consult STEWARTS

WARNING – For Your Safety—USER RESPONSIBILITY

FAILURE OR IMPROPER SELECTION OR IMPROPER USE OF THE PRODUCTS DESCRIBED HEREIN OR RELATED ITEMS CAN CAUSE DEATH, PERSONAL INJURY AND PROPERTY DAMAGE.

This document and other information from Stewart-Buchanan, its subsidiaries and authorized distributors provide product or system options for further investigation by users having technical expertise.

IT IS SOLELY THE RESPONSIBILITY OF THE SYSTEM DESIGNER AND USER TO SELECT PRODUCTS SUITABLE FOR THEIR SPECIFIC APPLICATION REQUIREMENTS AND TO ENSURE PROPER INSTALLATION, OPERATION AND MAINTENANCE OF THESE PRODUCTS, MATERIAL COMPATABILITY, PRODUCT RATINGS AND APPLICATION DETAILS SHOULD BE CONSIDERED IN THE SELECTION.

The user through its own analysis and testing, is solely responsible for making the final selection of the system and components and assuring that all performance, endurance, maintenance, safety and warning requirements of the application are met. The user must analyse all aspects of the application; follow applicable industry standards; and follow the information concerning the product in the current product catalogue and in any other materials provided by Stewart-Buchanan or authorized distributors.

To the extent that Stewart-Buchanan or its subsidiaries or authorized distributors provide component or system options based upon data or specifications provided by the user, the user is responsible for determining that such data and specifications are suitable and sufficient for all applications and reasonably foreseeable uses of the components or systems.

(Please refer to our Guidance on Use of Equipment document).

OFFER OF SALE

The items described in this document are hereby offered for sale by Stewart-Buchanan its subsidiaries or its distributors. Any order accepted by Stewart-Buchanan will be subject to our terms and conditions of sale, copy available on www.stewarts-group.com, or by request.



Stewarts - USA, LLC

6786 Tipperary, Houston, Texas 77061 USA
info@stewartsusa.com

Phone: 713.643.1022. Fax: 713.643.2855. Toll Free: 800.901.1316

Web: www.STEWARTSUSA.com





Quality Standards

- ISO 9001
- P.E.R 1999 (S2001)
- P.E.D 97/23/EC
- MOD/DEF STAN - 66

On request , valves can be fire safe.
Constructed compliant with BS 6755 Pt 2. / ISO 10497
(Max 6000 psi (413 bar)) API 6FA, API 607.

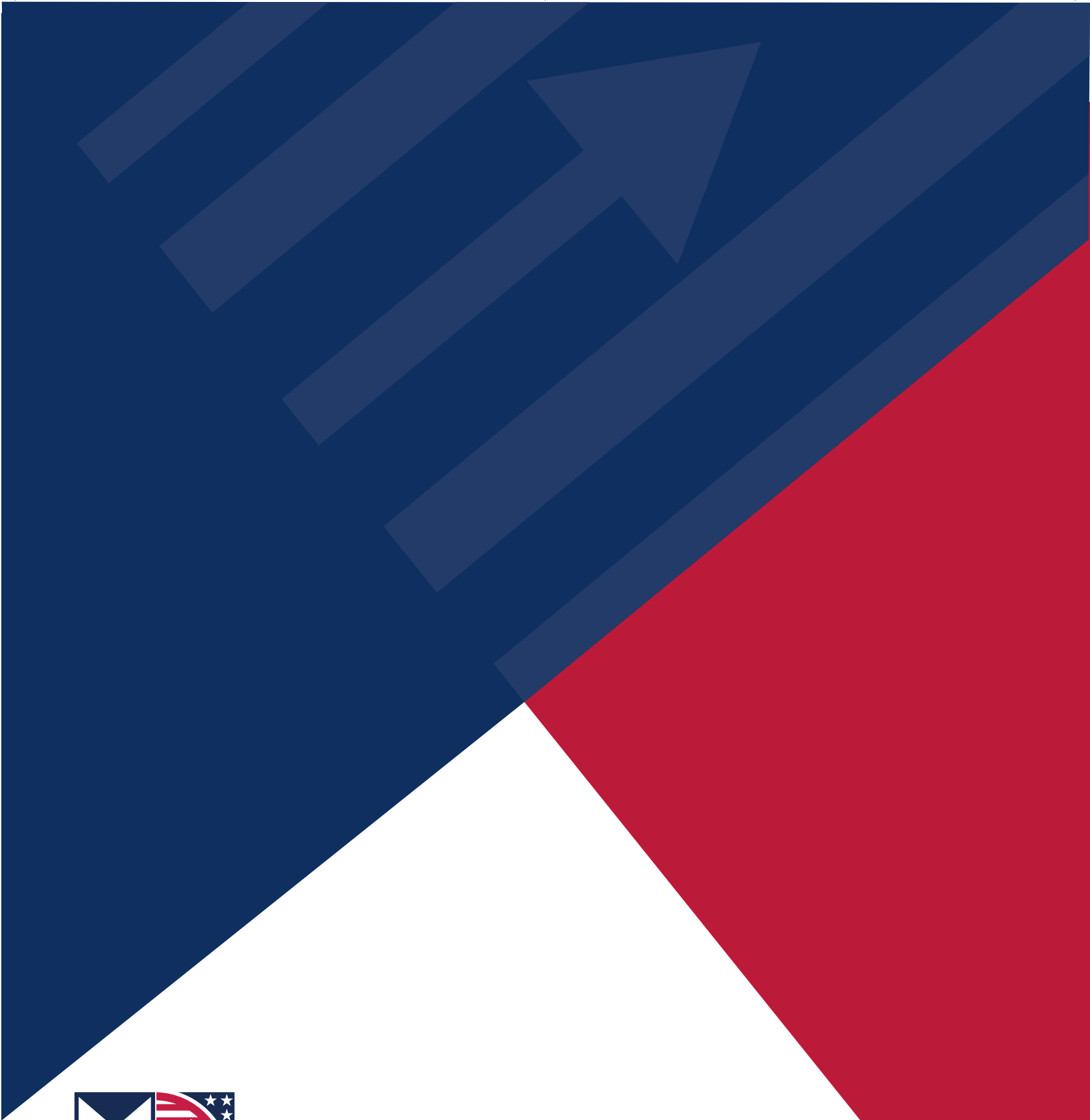

Stewarts - USA, LLC

6786 Tipperary, Houston, Texas 77061 USA

Phone: 713.643.1022. | Fax: 713.643.2855. | Toll Free: 800.901.1316 | Email: info@stewartsusa.com

WWW.STEWARTSUSA.COM

